



M-CONTROLLER

Multi-Channel Analog / Digital Controller

The M-Controller is a multi-channel controller and alarm unit that utilizes both digital and analog communications to interface with a maximum of 32 remote digital transmitter/sensors, and 8 analog transmitter/sensors. Common relay configurations include voting, averaging, delay on actuation and deactuation, normally/not-normally energized and latching. An additional feature includes 24 VDC transistor outputs for a horn and strobe. An RS-422 output responds as a RTU Slave using MODBUS protocol which allows the controller to provide read status information only. The M-Controller can be programmed with the onboard key pad or the M-View Software which is downloaded using the RS-232 interface. Also available is an analog output card that includes eight 4-20 mA analog outputs. Each analog output can be defined in complex fashions allowing

the averaging of several input signals and outputs a linear 4-20 mA signal.

M-Relay modules are designed to allow expandability for control to the M-Controller over an RS-485 communication link, which allows flexibility during installation and wiring. M-Relays operate on 24 VAC/VDC and may be powered via the port power of the M-Controller or directly from a local power source. Each relay module is addressed from 0 to 11 and is defined by a four position dipswitch. The M-Controller has three relays (1, 2, 3) after which the M-Relay can be added and will correspond with 4 through 99. The M-Relay module is available with 2, 4, 6, or 8 relays per module. Refer to all applicable Federal, State, Provincial and Local Health and Safety laws and regulations before using these products.

Applications: Underground Parking Garages, Water Treatment Plants, Municipal Service Garages, Aircraft Hangers, Chiller Monitoring, Warehouses, Automobile Dealerships & Battery Charging / Storage

The M-Controller is covered by ACI's Two (2) Year Limited Warranty. The warranty can be found in the front of ACI's Sensors & Transmitters catalog, as well as on ACI's web site, workaci.com.

PRODUCT SPECIFICATIONS

Supply Voltage:	24 VAC +/- 4V Floating; AC must not be grounded 24 VDC +/- 4V
Amps:	Controller: 1.0 A Horn & Strobe: 0.6 A Maximum Load per Channel: 2.0 A Maximum Allowed through Controller: 10.0 A
Operating Temperature:	-4°F to 122°F (-20°C to 50°C)
Operating Humidity:	5% to 95% RH Continuous non-condensing
Programming:	On-board keypad or M-View software (software and RJ-11 to serial cable included)
Communication Protocol:	Modbus Slave using Modbus RTU RS-422 port to host computer
RJ-11 Telephone Jack:	RS232 interface for uploading or downloading large configuration data bases using M-View Software can be used for Modbus RTU communication with BAS
Inputs:	Digital: 4 Parallel RS-485 ports allow up to 32 QEL gas sensors, and up to 99 relays Analog: 8 channels of 4-20 mA inputs with one common
Outputs:	Optional 8 analog channels of 4-20 mA signals with one common
Indicators:	5 Red LEDs: 3 Relay status, Hush and Fault
Display:	2 x 16 character display with backlight
Keypad:	4 x 4 tactile & audible keypad
On-Board Relays:	Three DPDT Form C, Dry Contact 5.0A resistive 240 VAC, 30 VDC 3.7A inductive 240 VAC, 30 VDC
Relay Life Expectancy:	Mechanical: Minimum 5,000,000
Time Delays:	Actuation / De-Actuation: 0 to 60 minutes
On-Board Buzzer:	90 db @ 12" (30 cm), 2700 Hz; 3 Buzzer tones
Horn & Strobe:	Two 24 VDC terminals provided 6 Watts each
Storage:	32°F to 68°F (0°C to 20°C) 0 to 99% RH Non-Condensing
Enclosure:	Steel, epoxy painted black, NEMA 1
Dimensions:	(H) 10.00" (254 mm) x (W) 8.00" (203 mm) x (D) 2.00" (51 mm)
Terminal Blocks:	Fixed, Power Wiring: 16 to 26 AWG (0.2 to 1.00 mm ²) Twisted Pair
Terminal Block Torque Rating:	0.37 ft-lbs (0.5n-3m) Nominal
Communication Wiring:	Belden 9841 or equal
Shipping Weight:	5.00 lbs (2268 g)
Options:	'P': Professional version of software for real time monitoring and data logging Horn & Strobe: See workaci.com/accessories/strobe and alarm Analog Output Card: 8 channel analog output with one common, 4-20 mA NEMA 4X Enclosure: Polycarbonate, flammability rating UL94V-0
Agency Approvals:	CSA NRTL/C, C22-205

Note: Sensors and system should be scheduled to be tested for accuracy and functionality every 6 months for toxic, and every 3 months for combustible | Recalibrate or replace sensor boards if necessary





DIMENSIONAL DRAWING

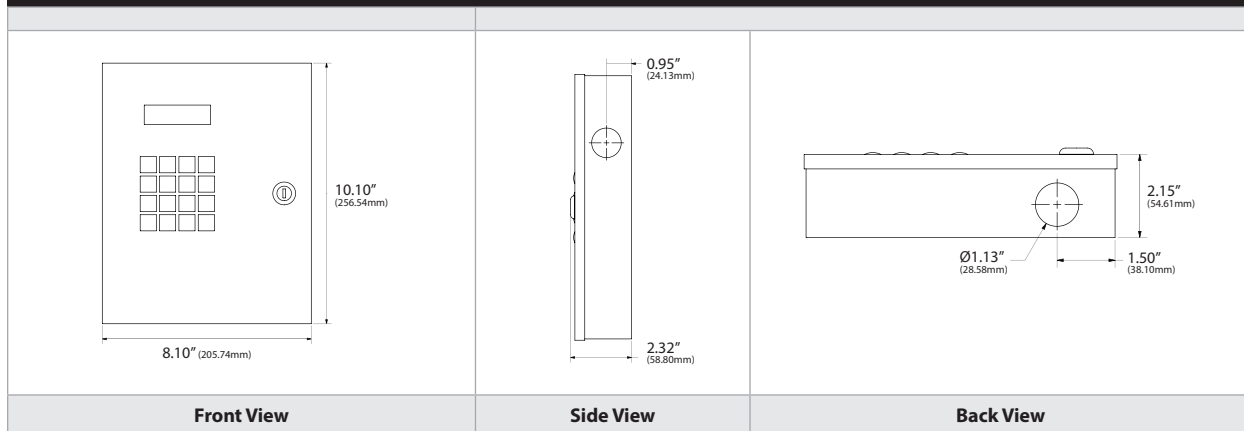

STANDARD ORDERING

Model # Example: **M-CONTROLLERX-000** -OR- **125945**

Model #	Item #	Description
M-CONTROLLERX-000	125945	M-Controller with M-View Software
M-CONTROLLERX-00P	142957	M-Controller with M-View Software & Real Time Monitoring
M-CONTROLLERX-T00	128896	M-Controller with M-View Software, Analog Output Card (Eight (8) 4-20 mA Output Channels)

ACCESSORIES ORDERING

Model # Example: **M-SWITCH** -OR- **127160**

Model #	Item #	Description
84330-013-000	126147	M-Controller Programming Cable (Included with M-Controller)
84330-014-000	132781	M-View CD for M-Controller / Q4C Controller
84330-101-00	137163	8 Channel Analog Output Card
84330-621-000	149993	NEMA 4X Enclosure for M-Controller
M-ANNUNCIATOR	135212	Annunciator Panel for M-Controller
M-RELAY-5X-2	125946	Relay, 2DPDT, 5 Amps for M-Controller
M-RELAY-5X-4	125947	Relay, 4DPDT, 5 Amps for M-Controller
M-RELAY-5X-6	138717	Relay, 6DPDT, 5 Amps for M-Controller
M-RELAY-5X-8	125948	Relay, 8DPDT, 5 Amps for M-Controller
M-SWITCH	127160	Manual Input Switch for M-Controller / Q4C Controller
M-TRANSFORMER	127162	Industrial Transformer, closed type, single phase, 120V to 24V, 250VA for M-Controller

ACCESSORIES ORDERING | HORN STROBE

Model # Example: **FSIG-SLM500A** -OR- **136476**

Model #	Item #	Description
FSIG-SLM500A	136476	Streamline Horn and Strobe (Amber)
FSIG-SLM500B	142976	Streamline Horn and Strobe (Blue)
FSIG-SLM500G	143013	Streamline Horn and Strobe (Green)
FSIG-SLM500R	143132	Streamline Horn and Strobe (Red)

ACCESSORIES ORDERING | MOUNTING BASE

Model # Example: **FSIG-SLMBW-012-024GY** -OR- **136477**

Model #	Item #	Description
FSIG-SLMBD-012-024GY	142977	Deep Base for FSIG-SLM500 Series; Gray
FSIG-SLMBW-012-024GY	136477	Wall Mount Base for FSIG-SLM500 Series; Gray

Note: See Strobe & Alarm Data Sheet if required

