

# L4064B, L4064R Universal Combination Fan and Limit Controllers

## INSTALLATION INSTRUCTIONS

### APPLICATION

These combination warm air fan and limit controllers are suitable for various types of forced air heating systems. The controllers have 2 switches; one which opens the limit circuit if the plenum temperature exceeds the preset safety limit; it resets automatically. The other switch turns the fan on and off. The fan is turned on and off according to plenum temperature. The L4064R has a special high temperature range suitable for gravity heating systems. All models may be used as limit controllers by wiring only the limit side. Limit contacts are suitable for both line voltage and low voltage. For low voltage applications, the brass jumper must be removed.

### OPERATION

As the plenum temperature rises, the coiled bimetal sensing element of the control warps and mechanically makes the fan contacts (at the FAN ON temperature setting). During normal operation, the call for heat ends before the LIMIT setting is reached and the fan contacts break as the plenum temperature falls and the FAN OFF setting is reached. If the call for heat continues until the temperature in the plenum rises to the LIMIT setting, the bimetal element will mechanically break the limit contacts and de-energize the heating control circuit.

### INSTALLATION

#### When Installing this Product...

1. Read these instructions carefully. Failure to follow them could damage the product or cause a hazardous condition.
2. Check the ratings given in the instructions and on the product to make sure the product is suitable for your application.
3. Installer must be a trained, experienced service technician.
4. For 230 VAC application, use of double insulated cable is required.
5. After installation is complete, check out product operation as provided in these instructions.

#### **WARNING**

**If limit switch is used on a low voltage circuit, failure to remove brass jumper can cause electrical shock hazard and/or damage to low voltage controls.**

#### **CAUTION**

1. Disconnect power supply before connecting wiring to prevent electrical shock or equipment damage.
2. When connecting cable or conduit to control, avoid straining the control case.

Follow furnace or burner manufacturer's instructions, if available. Maximum element temperature is:  
 L4064B—350 °F (177 °C).  
 L4064R—250 °F (121 °C) above limit setting.  
 Maximum switch temperature is:  
 L4064B,R—190 °F (88 °C).



Do not exceed the following electrical ratings (amperes):

**Table 1. Electrical Ranges**

	120 Vac		240 Vac	
	FAN	LIMIT	FAN	LIMIT
Full Load	14	8	7	4
Locked Rotor	84	48	42	24

Pilot Duty: 2 A at 24 Vac; 0.25 A at 0.25 to 12 Vdc.  
 Maximum Combined Connected Load: 2000 VA. 75 °C (167 °F) (min.) field wiring required. Wiring must conform to NEC Class 1 requirements.

**Approval**

- IP20 compliance
- CE pin number 0085BM0320, valid for B type.
- DIN Certco registration:  
 L4064B IS Classified as TR/TW;
- CSA certified file #LR1622
- UL listed file #LR1322-336

**LOCATION**

If this is a replacement installation, locate the L4064 in the same location as the control being replaced. Sensing tube length should be same as old control. If this is a new installation, the element should be installed only by a trained, experienced service technician according to the furnace manufacturer's instructions. The element must not touch any internal part of the furnace.

**NOTE: The electrical rating is at maximum switch temperature of 190 °F (88 °C). If plenum surface temperature exceeds 190 °F (88 °C), heat insulating material or mounting bracket must be used.**

**MOUNTING**

The devices may be mounted as follows:  
 L4064B — Swivel mount  
 L4064R — Swivel mount

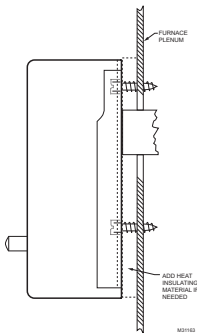

**Fig. 1. Surface mounting for L4064B requires a 13/16 in. (20.6 mm) hole.**

**Surface Mounting (Fig. 1)**

L4064B—Hole in plenum should be just large enough to accommodate the 3/4 in. (19.1 mm) diameter element tube. A 13/16 in. (20.6 mm) diameter hole is recommended.

1. Remove cover by removing screw, squeezing sides and pulling off. Insert element in plenum and mark location of mounting holes. Make sure the case is snug against the plenum before marking the mounting holes.
2. Punch or drill holes for mounting screws.
3. Place insulation between plenum and case if necessary.
4. Fasten controller securely with mounting screws.

**Swivel Mounting (Fig. 2)**

The L4064B and L4064R may be swivel-mounted. The swivel bracket requires a 1-9/16 in. (39.7 mm) hole in the plenum.

1. Use bracket as a template to make the location of mounting holes in plenum. Drill or punch holes for mounting screws.
2. Fasten the bracket in place with furnished screws. Start the screws but do not tighten.
3. Insert element tube through bracket, straighten controller, and fasten. Tighten the mounting screws securely. It may be necessary to rotate the bracket to tighten all screws securely.

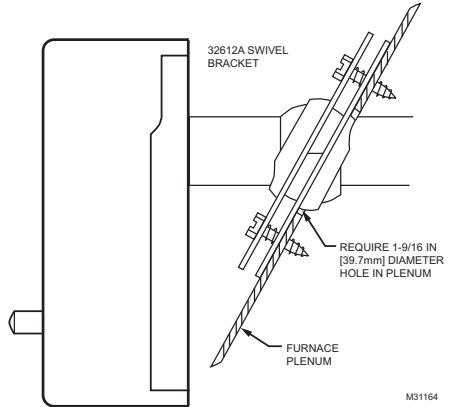

**Fig. 2. Swivel mounting requires a 1-9/16 in. (40 mm) diameter mounting hole for element insertion.**

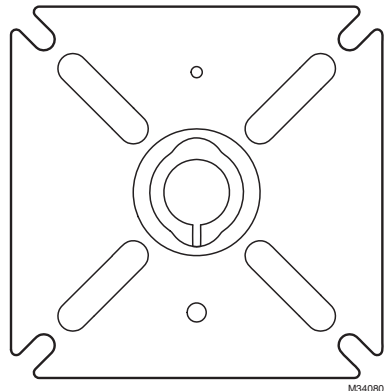

**Fig. 3. Swivel mount (front view).**

## WIRING

Disconnect power supply before beginning installation to prevent electrical shock or equipment damage. All wiring must comply with local electrical codes and ordinances or in the absence of local codes with the National Electrical Code ANSI CI-1981-NFPA 70. Follow burner or furnace manufacturer's instructions if available; otherwise, see Fig. 5 and proceed as follows.

### IMPORTANT

The brass jumper is the breakaway type. It must be removed when the limit is used in the low voltage circuit. To remove jumper, break with a needlenose pliers and remove completely. Once removed, it is not replaceable. See Fig. 5 for location.

1. If cable is used, we recommend using a strain-relief bushing in the knockout. Bushing is provided with control.
2. Refer to the following section for type of wiring connections (standard wire push-in terminals or female receptacle).

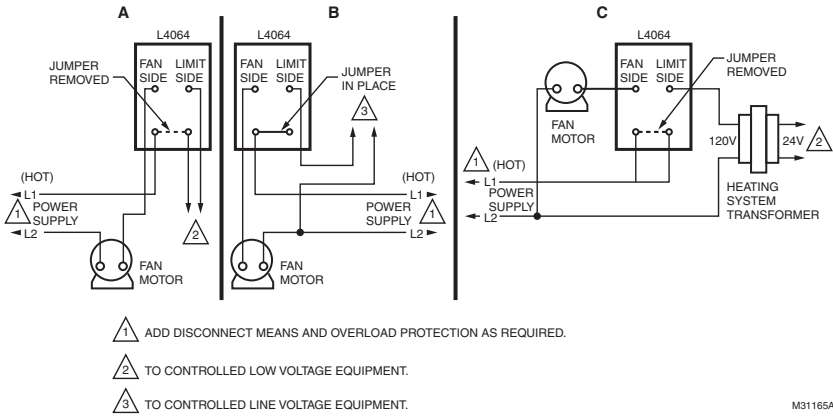

M31165A

Fig. 4. Wiring Diagram for L4064.

## Wiring Connections

When connecting cable or conduit to this controller, use care to avoid strain on the control case. Connections can be made to standard wire push-in terminals or female receptacles for 1/4 in. (6.4 mm) male flag connectors on both the fan and limit switches (Fig. 5).

### For Standard wire Push-in terminals

Connect wires to the terminals as follows:

1. Use Nos. 14, 16, or 18 solid wire or Nos. 14 or 16 stranded wire, depending on electrical requirement.
2. Strip insulation from wires the distance shown by the strip gauge on the controller. If wire insulation is 4/64 in. (2 mm) thick, strip additional 1/4 in. (6 mm) to ensure wire seats securely in push-in connectors.
3. Solid wire may be inserted directly into the terminal holes. If stranded wire is used, insert a small screwdriver into the slot next to the terminal. Push screw-

driver in and hold while inserting wire into terminal (Fig. 5). Remove screwdriver. If stranded wire is solder-dipped, it can be pushed directly into terminal holes.

### For Female Receptacles

It is recommended that the female receptacles be used for wiring accessory equipment; i.e., electronic air cleaner, humidifier, etc. Connect wires to the receptacles as follows:

1. Use Nos. 14 to 18 size wire, depending on electrical requirement.
2. Attach 1/4 in. (6.4 mm) male flag connector to each wire.
3. Push male flag connector directly into the female receptacle. Make sure that the flag is forced to the bottom of cavity and wire is in the channel (Fig. 5).

## CHECKOUT

When installation is complete, disconnect the fan motor circuit at the L4064. Turn on power and set thermostat to call for heat. Burner should come on and limit controller should shut burner off when plenum temperature reaches the limit set point. Turn off power, reconnect the fan switch, turn on power and again set thermostat to call for heat. The fan should start when plenum temperature has reached fan-on setting.

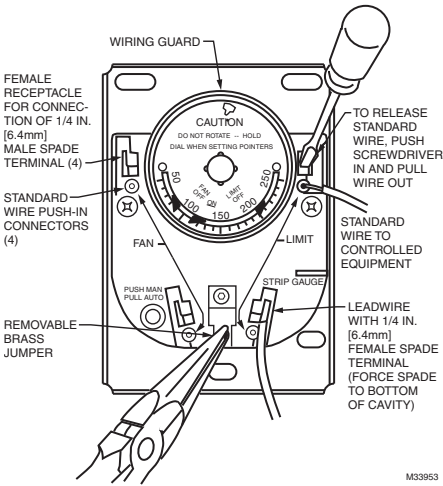

Fig. 5. Location of Wiring Connections.

### Fan Setting Adjustment

1. Move the FAN OFF lever to the temperature at which the fan is to stop to prevent circulation of cool air.
2. Move the FAN ON lever to the temperature at which the fan is to turn ON to circulate warm air.

### Manual Fan Switch

For constant fan operation (overriding fan setting levers), push the FAN switch button in. For fan to cycle automatically, pull button out.

### Limit Setting Adjustment

Move the limit lever to the temperature at which the high-limit switch will open to stop the burner.

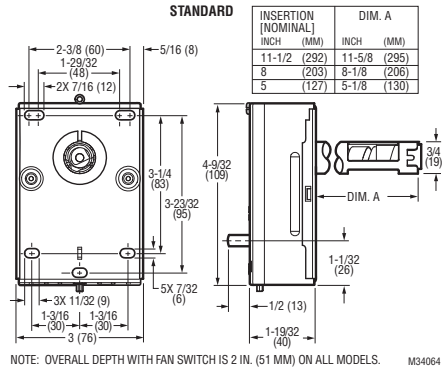

Fig. 6. L4064 Dimensions.

### Automation and Control Solutions

Honeywell International Inc.  
1985 Douglas Drive North  
Golden Valley, MN 55422  
customer.honeywell.com

