



SPECIFICATIONS

Rated rotary angle	90° (adjustable)
Nominal pressure rating	PN16
Flow characteristic	Equal percentage (See Fig.1)
Rangeability	300:1
Leakage rate	≤0.01% of k_{vs}
Valve body	
End connections	BSPP
Material	Cast Brass
Dimensions	See Fig.2
Trim	
Seat	Reinforced PTFE
Ball	Stainless Steel
Stem	Stainless Steel
Medium	Chilled and hot water
Working temperature	-5 ... 120 °C

GENERAL

These cast brass two-way ball valves are used for modulating control of hot / chilled water in heating, ventilating and air conditioning systems.

Honeywell CN7505A2001(5N.m), CN7510A2001(10N.m), CN7220A2007(20N.m) are recommended to be used with VBA216 series.

FEATURES

- Cast brass with BSPP.
- Low seat leakage rate.
- Spring supply seat for long life span.
- Excellent self-clean function.
- Accurate positioning to ensure state-of-the-art temperature control.
- Easy mounting of directly coupled with electric actuator.

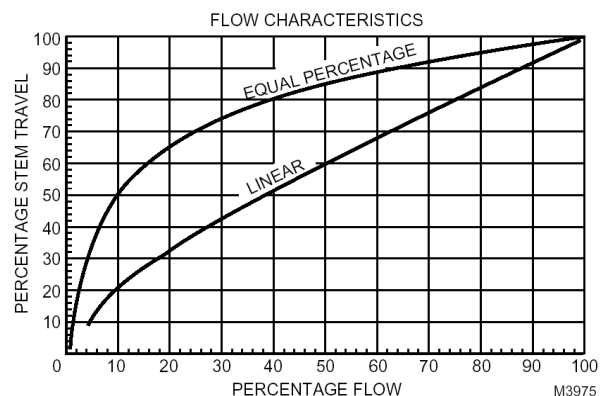

Fig. 1

SIZES AND FLOW CAPACITIES

Table 1. Sizes and flow capacities

Valve				Actuator
Order Number	Valve Size	Kvs	Close-off(bar)	Recommendatory Actuator Torque
VBA216-020P	DN20	6.3	14	5N.m
VBA216-025P	DN25	10	14	5N.m
VBA216-032P	DN32	16	14	5N.m
VBA216-040P	DN40	26	14	10N.m
VBA216-050P	DN50	41	14	10N.m
VBA216-065P	DN65	51	14	20N.m
VBA216-080P	DN80	81	14	20N.m

DIMENSIONS

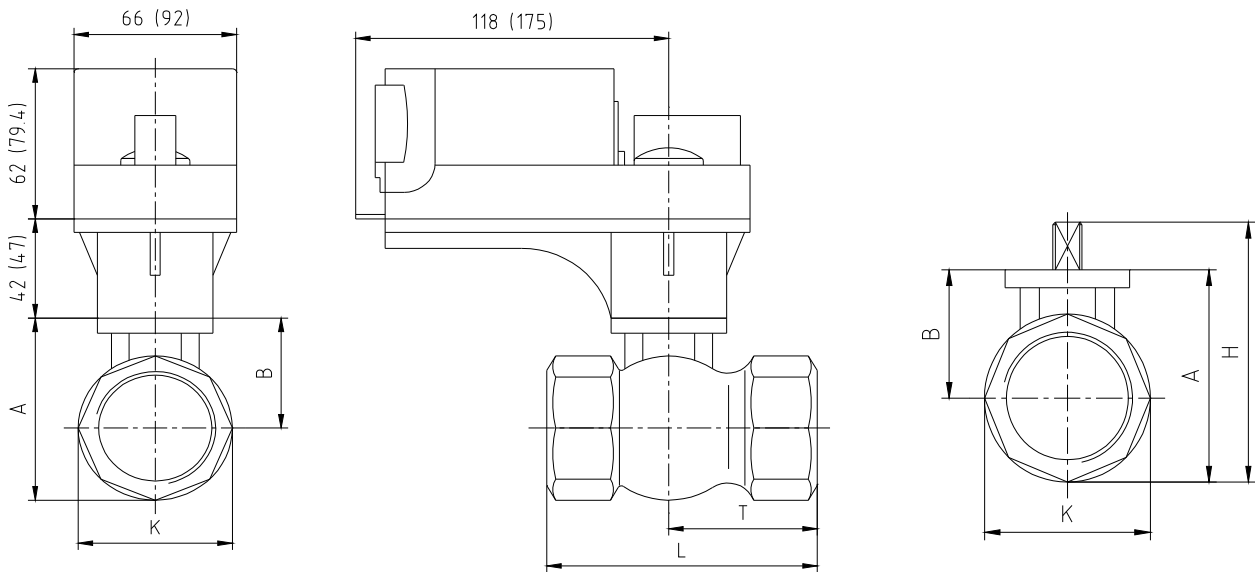

Fig. 2

OS#	DN		L	T	K	A	B	H
	mm	In						
VBA216-020P	20	¾	60	34	38	49.5	30.5	60.5
VBA216-025P	25	1	65	38.5	44	56	34	67
VBA216-032P	32	1 ¼	75	45	54	65	38	76
VBA216-040P	40	1 ½	85	51.5	60	78	48	89
VBA216-050P	50	2	95	56.5	73	90	53.5	101
VBA216-065P	65	2 ½	115	63.5	92	110	64	122
VBA216-080P	80	3	130	83	109	127.5	73	140

INSTALLATION

- Vertical installation of horizontal piping or horizontal installation of vertical piping.
- When mounting the actuator in the fields, before installing the actuator, use an adjustable wrench to manually rotate the valve stem several times. This rotation breaks the torque that may have built up during long-term storage.
- Pay attention to medium flow direction, make sure the valve to move in the proper direction, wire the input lines to the electric actuator correctly.



Printed in China.
 Subject to change without notice.
 APEN0H-034CH33C0509

CENTRA[®]
LINE
 by Honeywell