

1749P01

QAA20..1

QAA2061D

Symaro™

Room Temperature Sensors

QAA20..1..

- Active sensors for acquiring the room temperature
- Operating voltage AC 24 V or DC 13.5...35 V
- Signal output DC 0...10 V or 4...20 mA

Use

In heating, ventilation and air conditioning plants for acquiring the room temperature.

Type summary

Type reference	Measuring range	Operating voltage	Output signal
QAA2061	0...50 °C	AC 24 V ±20 % / DC 13.5...35 V	DC 0...10 V
QAA2061D			
QAA2071	0...50 °C	DC 13.5...35 V	4...20 mA

Ordering and delivery

When ordering, please give name and type reference, e.g.:
Room temperature sensor **QAA2061**.

Equipment combinations

All systems or devices capable of acquiring and handling the sensor's DC 0...10 V or 4...20 mA output signal.

Function

The sensor acquires the room temperature via its sensing element whose resistance value changes as a function of the temperature. This change is converted to a DC 0...10 V or 4...20 mA output signal, depending on the type of sensor. The output signal corresponds to the selected temperature range.

Burden diagram

Output signal, terminal I1

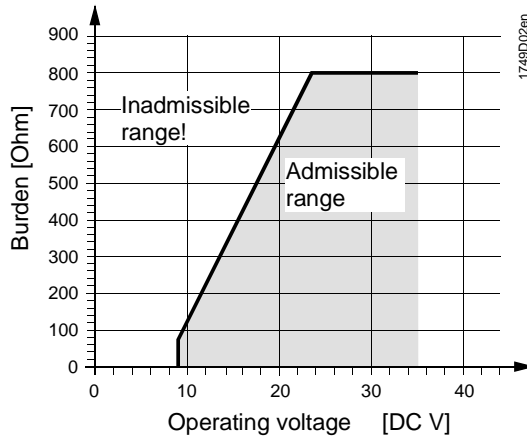

Mechanical design

QAA20..1

The units have been designed for wall mounting. They are suitable for use with most commercially available recessed conduit boxes. The cables can be introduced from the rear (concealed wiring) or from below or above (surface-run wires) through knock-out openings. The units consist of two major sections: Casing and baseplate. Both snap together but can be detached again. The measuring circuit, the sensing element and the setting element are located on the printed circuit board inside the casing. The baseplate carries the connecting terminals.

QAA2061D

Mechanical design is similar to QFA20... with additional LC-Display. Display of room temperature in °C or °F

Setting element

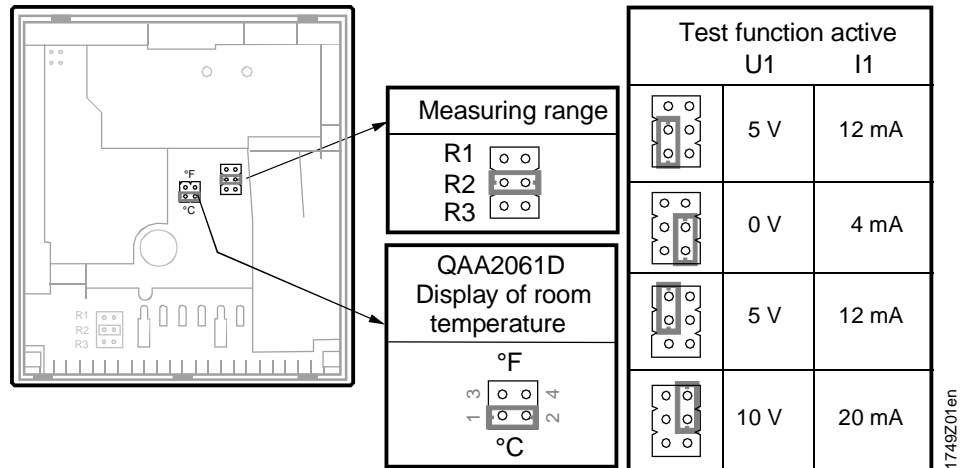

The setting element is accessible after removing the baseplate. It consists of 6 pins and a shorting plug. It is used to select the required measuring range and to activate the test function.

The different plug positions have the following meaning

- For the active temperature measuring range:
Shorting plug in the upper position (R1) = -35...+35 °C,

Shorting plug in the mid position (R2) = 0...50 °C (factory setting)

Shorting plug in the lower position (R3) = -50...+50 °C

- *For activating the test function:*

Shorting plug in the vertical position: The values according to the table "Test function active" will be made available at the signal output.

Fault In the event of fault, the output signal will reach 0 V (4 mA) after 60 seconds.

Disposal The major plastic components bear the material references in compliance with ISO / DIS 11469 to facilitate environment-friendly disposal.

Engineering notes

To power the sensor, a transformer for safety extra low-voltage (SELV) with separate windings for 100 % duty is required. When sizing and electrically protecting the transformer, local safety regulations must be observed.

When sizing the transformer, the power consumption of the outside temperature sensor must be taken into consideration. For correct wiring, refer to the Data Sheets of the devices with which the sensor is used.

The permissible cable lengths must be observed.

Cable routing and cable selection

When laying the cables, it must be observed that the longer the cables run side by side and the smaller the distance between them, the greater the electrical interference. Twisted pair cables are required for the secondary supply lines and the signal lines.

Mounting notes

Location On an inner wall of the space to be heated or air conditioned. Not in recesses, shelves, not behind curtains, not opposite or near heat sources.

The unit must not be exposed to direct solar radiation.

The end of the conduit at the sensor must be sealed to prevent false measurements due to draughts through the conduit.

The permissible ambient conditions should be observed.

Installation instructions Installation instructions are printed on the inside of the packing.

Commissioning notes

Check wiring before switching on power. The temperature measuring range must be selected on the sensor, if required.

Technical data

Power supply	Operating voltage	refer to "Type summary"
	Frequency	50/60 Hz at AC 24 V
	Power consumption	≤ 1 VA
Line lengths for measuring signal	Perm. cable lengths	
	Copper cable 0.6 mm dia.	50 m
	Copper cable 1 mm ²	150 m
	Copper cable 1.5 mm ²	300 m
Functional data	Measuring range	0...50 °C (R2 = factory setting), -35...+35 °C (R1), -50...+50 °C (R3)
	Sensing element	Pt 1000
	Time constant	approx. 7 min
	Measuring accuracy in the range of	
	-25...+25 °C	± 0.75 K
	-50...+50 °C	± 0.9 K
	Output signal, linear (terminal U1)	DC 0...10 V $\hat{=}$ 0...50 °C or -35...+35 °C or -50...+50 °C max. ± 1 mA
	Output signal, linear (terminal I1)	4...20 mA $\hat{=}$ 0...50 °C or -35...+35 °C or -50...+50 °C
	Burden	refer to "Function"
Protective data	Degree of protection of housing	IP 30 to IEC 529
	Safety class	III to EN 60 730
Electrical connections	Connection terminals for	1 × 2.5 mm ² or 2 × 1.5 mm ²
Environmental conditions	Operation	IEC 721-3-3
	Climatic conditions	class 3K5
	Temperature (housing with electronics)	-15...+50 °C
	Humidity	0...95 % r. h. (non-condensing)
	Mechanical conditions	class 3M2
	Transport	IEC 721-3-2
	Climatic conditions	class 2K3
Temperature	-25...+70 °C	
Humidity	< 95 % r. h.	
Mechanical conditions	class 2M2	
Materials and colors	Housing front	ASA+PC, NCS S 0502-G (withe)
	Bottom	ASA+PC, NCS 2801-Y43R (grey)
	Base	PC, NCS 2801-Y43R (grey)
	Packaging	corrugated cardboard
	Sensor (complete assembly)	silicone-free
Standards	Product safety	
	Automatic electrical controls for household and similar use	EN 60 730-1
	Electromagnetic compatibility	
	Immunity	EN 61 000-6-2
	Emissions	EN 61 000-6-3
	CE conformity to	EMC Directive 89/336/EEC
	C conformity to	
Australian EMC Framework Radio Interference Emission Standard	Radio Communication Act 1992 AS/NZS 3548	
Weight	Incl. packaging	0.13 kg

Connection terminals

QAA2061
QAA2061D

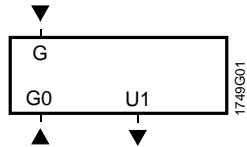

QAA2071

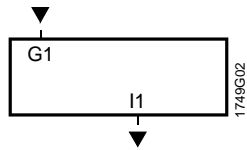

- G, G0 Operating voltage AC 24 V (SELV) or DC 13.5...35 V
- G1 Operating voltage DC 13.5...35 V
- I1 Signal output 4...20 mA for temperature range (R2 = 0...50 °C, factory setting)
- U1 Signal output DC 0...10 V for temperature range (R2 = 0...50 °C, factory setting)

Dimensions

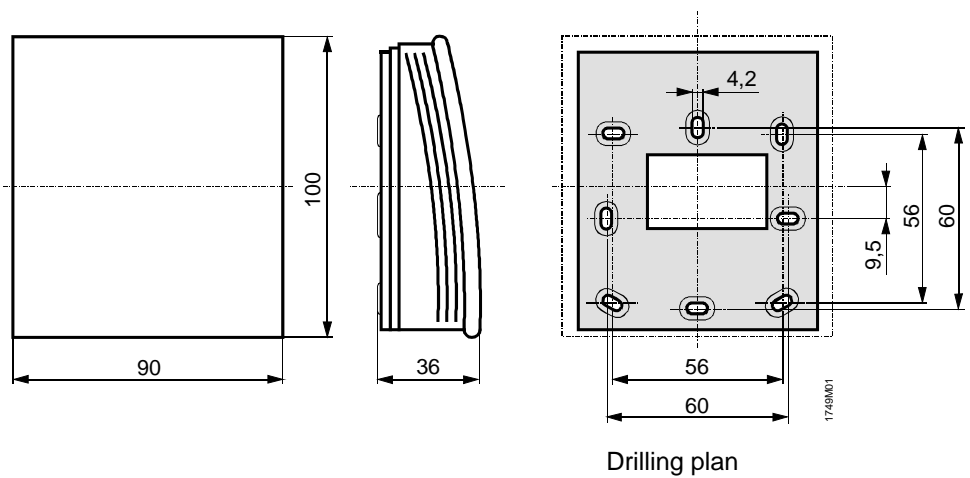

Dimensions in mm