



QFM31..

1882P01

QFM3160D /QFM3171D

1859P02

AQF3150

1859P04

AQF3153

Symaro™

## Duct sensors

QFM31...

for relative humidity (high accuracy) and temperature

- Operating voltage AC 24 V / DC 13.5...35 V
- Signal output DC 0...10 V / 4...20 mA for relative humidity and temperature
- Very high measuring accuracy across the entire measuring range
- Function test
- Capacitive humidity measurement
- Range of use  $-40...+70\text{ °C}$  /  $0...100\text{ % r. h.}$   
with LCD display  $-25...+70\text{ °C}$  /  $0...100\text{ % r.h.}$

### Use

The QFM31... is for use in ventilation and air conditioning plants where high accuracy and short response times for measuring relative humidity are required. The measuring range covers the entire humidity range of  $0...100\text{ %}$ .

### Examples

- Storage and production facilities in the paper, textile, pharmaceutical, food, chemical and electronics industry, etc.
- Laboratories
- Hospitals
- Computer and EDP centers
- Indoor swimming pools
- Greenhouses

The QFM31... is used as a

- control sensors in the supply or extract air
- limit sensor for maximum limitation of supply air humidity after a steam humidifier
- limit sensor, e.g. for measured value indication or for connection to a building automation and control system
- sensor for enthalpy and absolute humidity, together with the SEZ220 (see Data Sheet N5146)

## Type summary

| Type reference  | Temperature measuring range             | Temperature signal output | Humidity measuring range | Humidity signal output | Operating voltage         | Measured value display |
|-----------------|---|---------------------------|--------------------------|------------------------|---------------------------|------------------------|
| <b>QFM3100</b>  | None                                    | None                      | 0...100 %                | active, DC 0...10 V    | AC 24 V or DC 13,5...35 V | No                     |
| <b>QFM3101</b>  | None                                    | None                      | 0...100 %                | active, 4...20 mA      | DC 13,5...35 V            | No                     |
| <b>QFM3160</b>  | 0...50 °C / -40...+70 °C / -35...+35 °C | active, DC 0...10 V       | 0...100 %                | active, DC 0...10 V    | AC 24 V or DC 13,5...35 V | No                     |
| <b>QFM3160D</b> | 0...50 °C / -40...+70 °C / -35...+35 °C | active, DC 0...10 V       | 0...100 %                | active, DC 0...10 V    | AC 24 V or DC 13,5...35 V | Yes                    |
| <b>QFM3171</b>  | 0...50 °C / -40...+70 °C / -35...+35 °C | active, 4...20 mA         | 0...100 %                | active, 4...20 mA      | DC 13,5...35 V            | No                     |
| <b>QFM3171D</b> | 0...50 °C / -40...+70 °C / -35...+35 °C | active, 4...20 mA         | 0...100 %                | active, 4...20 mA      | DC 13,5...35 V            | Yes                    |

## Ordering and delivery

When ordering, please give name and type reference, e.g.:

Duct sensor **QFM3160**

Place a separate order for the service set AQF3153 listed under accessories.

## Equipment combinations

All systems and devices capable of acquiring and handling the sensor's DC 0...10 V or 4...20 mA output signal.

When using the sensors for minimum or maximum selection, for averaging, or to calculate enthalpy, enthalpy difference, absolute humidity, and dew point, we recommend to use the SEZ220 signal converter (see Data Sheet N5146).

## Technical design

### Relative humidity

The sensor acquires the relative humidity in the air duct via its capacitive humidity sensing element whose capacitance varies as a function of the relative humidity of the ambient air.

An electronic circuit converts the sensor's signal to a continuous DC 0...10 V or 4...20 mA signal, corresponding to a relative humidity of 0...100 %.

### Temperature

The sensor acquires the temperature in the air duct via its sensing element whose electrical resistance changes as a function of the temperature.

This variation is converted to an active DC 0...10 V or 4...20 mA output signal, depending on the type of sensor. The output signal corresponds to a selectable temperature range of 0...50 °C, -35...+35 °C, or -40...+70 °C.

### Burden diagram

Output signal, terminal I1 / I2

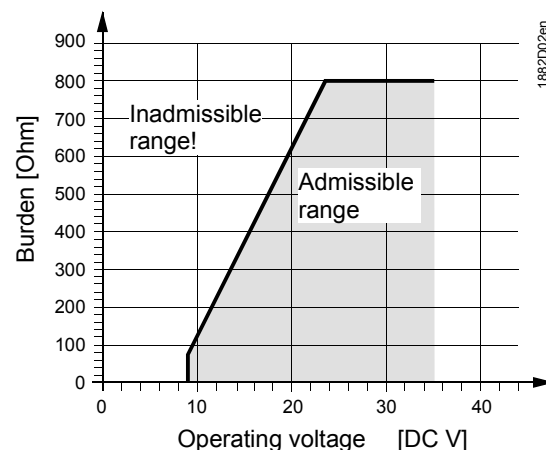

The duct sensor consists of a housing, a printed circuit board, connection terminals, a mounting flange and an immersion rod having a measuring tip.  
 The two-part housing comprises a base and a screwed removable cover.  
 A rubber seal is installed between the base and the cover in order to satisfy the requirements of IP 65 degree of protection.  
 The measuring circuit and the setting element are accommodated on the printed circuit board inside the cover, the connection terminals on the base.  
 The measuring tip is screwed on the immersion rod of the housing.  
 The sensing elements are located at the end of the measuring tip and protected by the filter cap.  
 Cable entry is made via the cable entry gland M16 (IP 54) supplied with the sensor, which can be screwed into the housing.  
 Immersion rod and housing are made of plastic and rigidly connected.  
 The sensor is fitted with the mounting flange supplied with the sensor. The flange is to be placed over the immersion rod and then secured in accordance with the required immersion length.

**Measured value display**

The types QFM3160D and QFM3171D provide the measured values on its LCD display..The following measured values are displayed alternately in intervals of 5 s:  
 Temperature: in °C or °F  
 Humidity: in % r. h.

**Setting element**

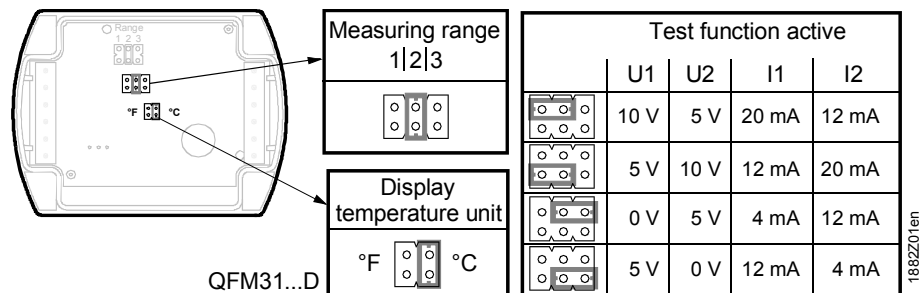

The setting elements are located inside the cover. A setting element consists of 6 pins and a jumper. It is used for selecting the required temperature measuring range and for activating the test function. Types with LCD display have a second setting element with 4 pins and a jumper.

The different jumper positions have the following meaning:

- **For the active temperature measuring range:**  
 Jumper in the left position (R1) = -35...+35 °C,  
 Jumper in the middle position (R2) = 0...50 °C (factory setting)  
 Jumper in the right position (R3) = -40...+70 °C
- **For the active test function:**  
 Jumper in the horizontal position: The values available at the signal output are those given in the table "Test function active"
- **For the measured value display (QFM31...D)**
  - Jumper vertical in the right position = °C (factory setting)
  - Jumper vertical in the left position = °F

**Malfunction**

- Should the temperature sensor become faulty a voltage of 0 V (4 mA) will be applied at signal output U2 (I2) after 60 seconds, and the humidity signal at signal output U1 (I1) will reach 10 V (20 mA).

- Should the humidity sensor become faulty a voltage of 10 V (20 mA) will be applied at signal output U1 (I1) after 60 seconds, and the temperature signal will remain active.

### Service set AQF3153

The service set comprises three measuring tips without sensor element. Each tip signals a predefined temperature and humidity value to the basic unit:

- 85 % r. h., 40 °C
- 50 % r. h., 23 °C
- 20 % r. h., 5 °C

The fixed values are available at the signal outputs. The accuracy of the values is the same as for the test function. The measuring tips can be exchanged in operation.

### Accessories

| <i>Name</i>                                  | <i>Type reference</i> |
|--|-----------------------|
| Filter cap (for replacement)                 | <b>AQF3101</b>        |
| Measuring tip (exchangeable for replacement) | <b>AQF3150</b>        |
| Service set (for function test)              | <b>AQF3153</b>        |
| 3 m cable for remote measurement             | <b>AQY2010</b>        |

### Engineering notes

A transformer for safety extra low-voltage (SELV) with separate windings for 100 % duty is required to power the sensor. When sizing and protecting the transformer, the local safety regulations must be complied with.

When sizing the transformer, the power consumption of the duct sensor must be taken into consideration.

For correct wiring of the sensor, refer to the Data Sheets of the devices with which the sensor is used.

The permissible line lengths must be considered.

#### Cable routing and cable selection

It must be considered for routing of cables that the longer the cables run side by side and the smaller the distance between them, the greater the electrical interference.

Shielded cables must be used in environments with EMC problems.

Twisted pair cables are required for the secondary supply lines and the signal lines.

#### Note to **QFM2171(D)**

Terminals G1(+) and I1(-) for the humidity output must always be connected to power, even if only terminals G2(+) and I2(-) of the temperature output are used!

### Mounting notes

#### Location

Mount the sensor in the center of the duct wall. If used together with steam humidifiers, the minimum distance after the humidifier must be 3 m to max 10 m.

Fit the sensor in the extract air duct if the application involves dew point shifting.

Fit only the flange to the duct wall. The sensor is then inserted through the flange and engaged.

#### Caution!

- The seal between base and cover must not be removed, or else degree of protection IP 65 will be no longer ensured.
- The sensing elements inside the measuring tip are sensitive to impact. Avoid any such impact on mounting.

#### Mounting instructions

Mounting Instructions are printed on the inner side of the package.

## Commissioning notes

Check wiring before switching on power. The temperature measuring range must be selected on the sensor, if required.

Wiring and the output signals can be checked by making use of the test function (refer to "Mechanical design").



We recommend not to use voltmeters or ohmmeters directly at the sensing element. In the case of the simulated passive output signals, measurements with commercially available meters cannot be made (measuring current too small).

### Technical data

|  |   |   |   |
|--|---|---|---|
| Power supply                           | Operating voltage   | AC 24 V $\pm$ 20 % or DC 13.5...35 V  |   |
|  | Frequency   | 50/60 Hz at AC 24 V   |   |
|  | Power consumption   | $\leq$ 1 VA   |   |
| Cable lengths for the measuring signal | Max. perm. cable lengths                                  | See data sheet of the device handling the signal                                    |   |
| Functional data<br>"Humidity sensor"   | Measuring range   | 0...100 % r.h.  |   |
|  | Measuring accuracy at 23 °C and AC 24 V<br>0...100 % r.h. | $\pm$ 2 % r. h.   |   |
|  | Temperature dependency                                    | $\leq$ 0.05 % r.h./°C   |   |
|  | Time constant   | < 20 s  |   |
|  | Supply air velocity                                       | 20 m/s  |   |
|  | Output signal, linear (terminal U1)                       | DC 0...10 V $\hat{=}$ 0...100 % r.h.<br>max. $\pm$ 1 mA                             |   |
|  | Output signal, linear (terminal I1)<br>Burden             | 4...20 mA $\hat{=}$ 0...100 % r.h.<br>See "Function"                                |   |
|  | Functional data<br>"Temperature sensor"                   | Measuring range   | 0...50 °C (R2 = factory setting),<br>-35...+35 °C (R1), -40...+70 °C (R3) |
|  |   | Sensing element   | Pt 1000   |
|  |   | Measuring accuracy at AC 24 V in<br>23 °C   | $\pm$ <0.5 K  |
| 15...35 °C                             |   | $\pm$ 0.6 K   |   |
| -35...+70 °C                           |   | $\pm$ 0.8 K   |   |
| Time constant                          |   | < 3.5 min. in with 2 m/s moved air  |   |
| Output signal, linear (terminal U2)    |   | DC 0...10 V<br>$\hat{=}$ 0...50 °C / -35...+35 °C / -40...+70 °C<br>Max. $\pm$ 1 mA |   |
| Degree of protection                   | Output signal, linear (terminal I2)<br>Burden             | 4...20 mA $\hat{=}$ 0...50 / -35...+35 / -40...+70 °C<br>See "Function"             |   |
|  | Housing   | IP 65 to IEC 60 529 in the built-in state   |   |
| Electrical connections                 | Safety class  | III to EN 60 730  |   |
|  | Screw terminals   | 1 $\times$ 2.5 mm <sup>2</sup> or 2 $\times$ 1.5 mm <sup>2</sup>                    |   |
| Environmental conditions               | Cable entry gland (enclosed)                              | M 16 x 1.5  |   |
|  | Operation to  |   |   |
| Materials and color                    | Climatic conditions                                       | Class 4K2 to IEC 60 721-3-4   |   |
|  | Temperature (housing with electronics)                    | -40...+70 °C  |   |
|  | LCD display readable                                      | -25...+70 °C  |   |
|  | Humidity  | 0...100 % r. h. (with condensation)   |   |
|  | Mechanical conditions                                     | Class 3M2 to IEC 60 721-3-3   |   |
|  | Transport to  | IEC 60 721-3-2  |   |
|  | Climatic condition  | Class 2K3   |   |
|  | Temperature   | -40...+70 °C  |   |
|  | Humidity  | <95 % r. h.   |   |
|  | Mechanical conditions                                     | Class 2M2   |   |
| Materials and color                    | Base  | Polycarbonate, RAL 7001 (silver-grey)   |   |
|  | Cover   | Polycarbonate, RAL 7035 (light-grey)  |   |
|  | Immersion rod   | Polycarbonate, RAL 7001 (silver-grey)   |   |
|  | Filter cap  | Polycarbonate, RAL 7001 (silver-grey)   |   |
|  | Mounting flange   | PA66 – GF35 (black)   |   |
|  | Cable entry gland   | PA, RAL 7035 (light-grey)   |   |

|                          |                               |   |
|--------------------------|-------------------------------|---|
| Standards and directives | Sensor (complete assembly)    | Silicone-free   |
|                          | Packaging                     | Corrugated cardboard  |
|                          | Product standard              | Automatic electrical controls for household and similar use<br>EN 60 730-1  |
|                          | Electromagnetic compatibility |   |
|                          | Immunity                      | EN 61 000-6-1   |
|                          | Emissions                     | EN 61 000-6-3   |
|                          | CE conformity to              | EMC directive 2004/108/EC   |
|                          | C-tick conformity (EMC) to    | EN 61 000-6-3   |
|                          | UL conformity                 | UL 873  |
|                          | Environmental compatibility   | Environmental product declaration CE1E1882en provides ISO 14001 (environment) information on environmentally compatible product design ISO 9001 (quality) and assessment (RoHS compliance, composition of substances, packaging, environmental benefit, disposal). SN 36350 (environmental comp. products) RL 2002/95/EC (RoHS) |
| Weight                   | Incl. packaging               |   |
|                          | Without LCD display           | 0.208 kg  |
|                          | With LCD display              | 0.225 kg  |
|                          | AQF3150                       | 0.050 kg  |
|                          | AQF3153                       | 0.066 kg  |

## Connection terminals

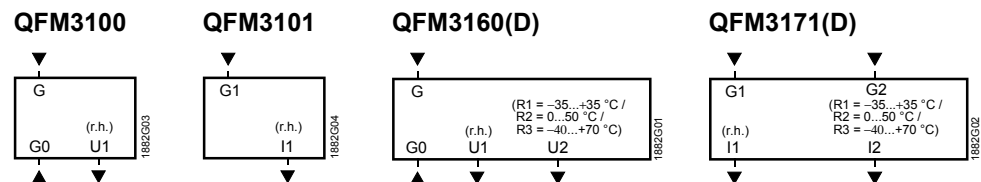

- G, G0 Operating voltage AC 24 V (SELV) or DC 13.5...35 V  
G1, G2 Operating voltage DC 13.5...35 V  
U1 Signal output DC 0...10 V for relative humidity 0...100 %  
U2 Signal output DC 0...10 V for temperature range 0...50 °C (R2 = factory setting),  
-35...+35 °C (R1) or -40...+70 °C (R3)  
I1 Signal output 4...20 mA for relative humidity 0...100 %  
I2 Signal output 4...20 mA for temperature range 0...50 °C (R2 = factory setting),  
-35...+35 °C (R1) or -40...+70 °C (R3)

**Note on connection terminals of the QFM3171(D):**

Terminals G1(+) and I1(-) for the humidity output must always be connected to power, even if only the temperature output G2(+) and I2(-) is used!

**Dimensions**

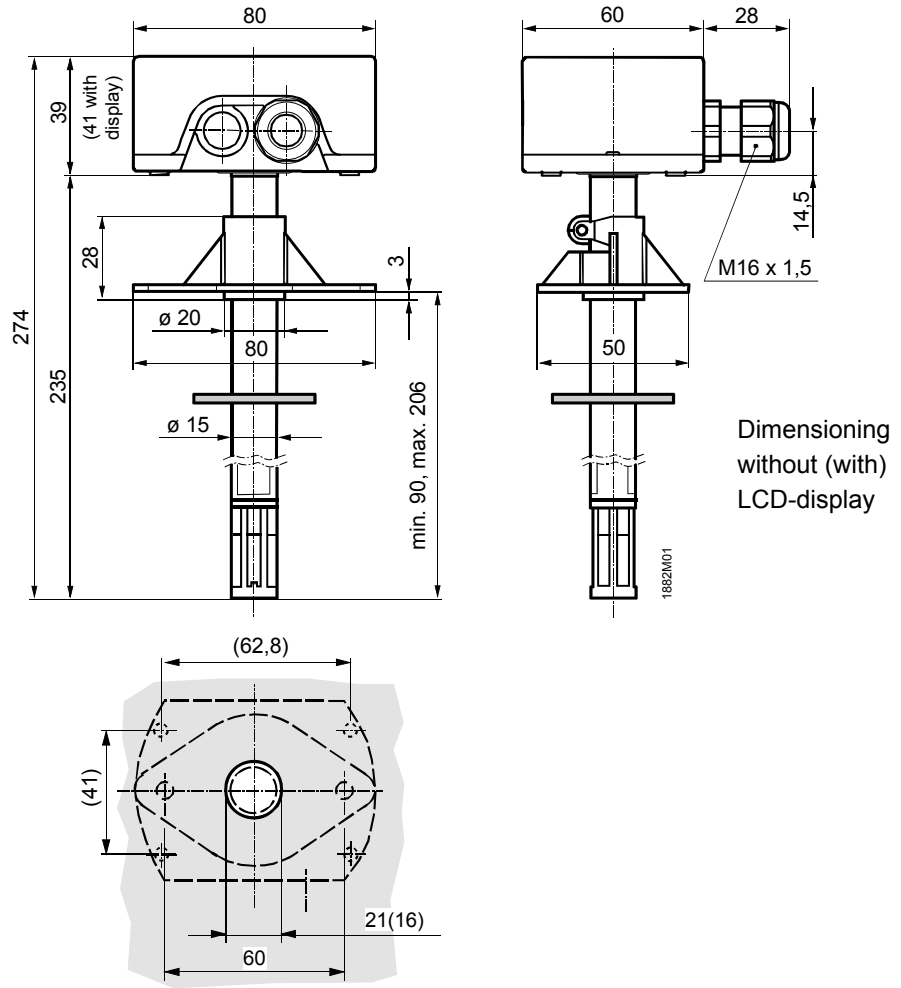

Drilling template with (without) mounting flange

Dimensions in mm