



QBM65-..., QBM65.2-...



QBM65.1-...

Differential pressure sensors

QBM65...

for air and nonaggressive gases

- With choice of pressure-linear or extracting-the-root characteristic with adjustable pressure measuring range
- Operating voltage AC 24 V or DC 13.5... 33 V
- Output signal DC 0...10 V

Use

For very demanding requirements with regard to accuracy and quality in the field of ventilation, air conditioning and heating. To acquire the differential pressure of air or nonaggressive gases.

Typical fields of application:

- Chemical industry (laboratories and production)
- In industrial environments (risk of contamination)
- In hospitals (e.g. in the operating theatre)

The differential pressure detectors are used:

- To measure over- or underpressure in air ducts in relation to the ambient pressure
- To measure pressure differentials between different rooms
- To acquire variable air volumes in VAV plants on the supply and extract air side
- To monitor filters and to control fans
- Especially on applications that demand:
 - great accuracy
 - very short response times (monitoring of fans)
 - nonsusceptibility to contamination

Type summary

Pressure-linear characteristic, without indication	Type reference	Measuring range		Overload range
		Standard	Limit value (adjustable)	
	QBM65-1U	-50... +50 Pa	No	5,000 Pa
	QBM65-1	0... 100 Pa	No	5,000 Pa
	QBM65-3	0... 300 Pa	No	5,000 Pa
	QBM65-5	0... 500 Pa	No	10,000 Pa
	QBM65-10	0...1,000 Pa	No	10,000 Pa
	QBM65-25	0...2,500 Pa	No	20,000 Pa

Pressure-linear characteristic, with indication	Type reference	Measuring range		Overload range
		Standard	Limit value (adjustable)	
	QBM65.1-1	0... .100 Pa	No	5,000 Pa
	QBM65.1-3	0... .300 Pa	No	5,000 Pa
	QBM65.1-5	0... .500 Pa	No	10,000 Pa
	QBM65.1-10 ¹⁾	0...1,000 Pa	No	10,000 Pa
	QBM65.1-25 ¹⁾	0...2,500 Pa	No	20,000 Pa

1) Value displayed x 10 = measured value

Extracting-the-root characteristic, without indication	Type reference	Measuring range		Overload range
		Standard	Limit value (adjustable)	
	QBM65.2-1	0... .100 Pa	40... 100 Pa	5,000 Pa
	QBM65.2-3	0... .300 Pa	120... 300 Pa	5,000 Pa
	QBM65.2-5	0... .500 Pa	200... 500 Pa	10,000 Pa
	QBM65.2-10	0...1000 Pa	400...1,000 Pa	10,000 Pa
	QBM65.2-25	0...2500 Pa	1,000...2,500 Pa	20,000 Pa

(Conversion: 100 Pa = 1 hPa = 1 mbar)

Accessories (not included in standard delivery)	Name	Type reference/part no.	Data sheet no.
	Duct probes, short	FK-PZ1	1589
	Duct probes, long	FK-PZ2	1589
	Mounting bracket	AQB21.1	

Ordering and delivery

When ordering, please give name and type reference, e.g. differential pressure sensor **QBM65.1-3**.

The differential pressure sensor is supplied complete with 2 m plastic tubing.

Accessories are to be ordered separately, with name and type reference or order number.

The duct probes are supplied only in pairs.

Equipment combinations

Any systems or devices that are capable of acquiring and handling the sensor's DC 0...10 V output signal.

The sensor acquires the differential pressure with the help of a silicon diaphragm. The deflection of the diaphragm is sensed and converted to an electric signal. With the extracting-the-root sensors, the potentiometer is used to match the pressure measuring range on an individual basis.

Depending on the type of sensor, the sensor's electronic circuit generates either a pressure-linear or extracting-the-root signal which is calibrated and temperature-compensated.

The measured value is delivered by the sensor as an analog DC 0...10 V output signal.

Overview of the characteristics and measuring accuracy at an ambient temperature of 20 °C:

Sensor characteristics and accuracy

Linearer output and total tolerances with a change of ± 10 °C

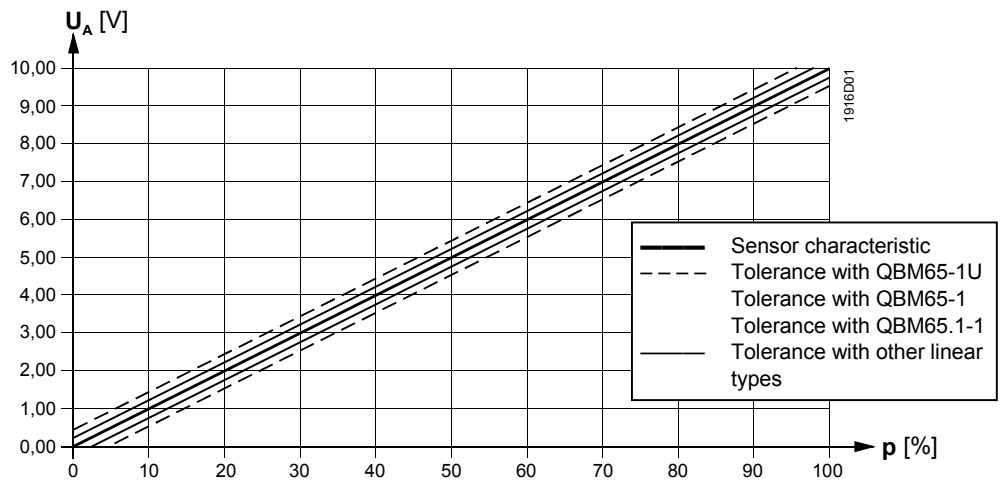

Extracting-the-root output and total tolerances with a change of ± 10 °C

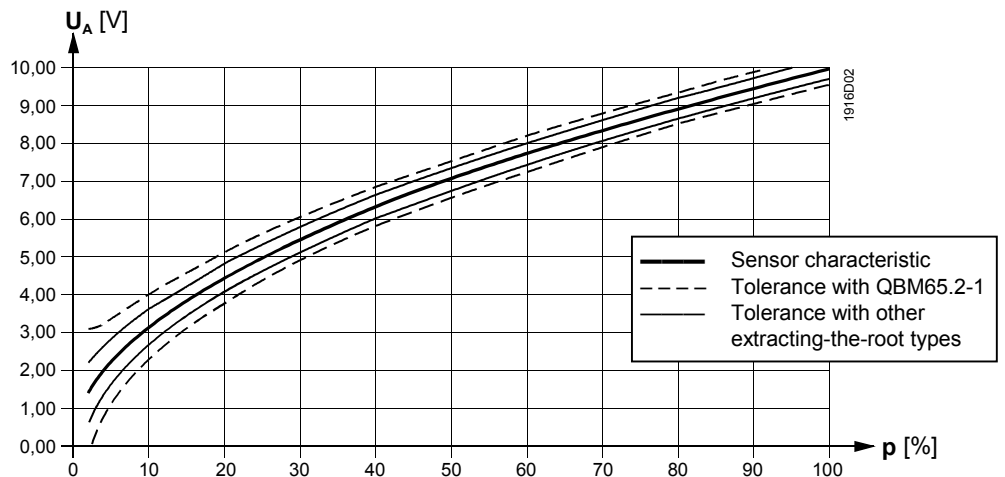

Legend

U_A Output voltage in V
 p Pressure measuring range in percent

For detailed information on accuracy, refer to "Technical data".

Mechanical design

The differential pressure sensor is designed for wall and ceiling mounting. It consists of:

- Sensor housing with mounting bracket, cable entry and removable snap-on cover with safety screw
- Pressure casing with diaphragm and lever
- Printed circuit board with connection terminals and – with the extracting-the-root sensor – with a potentiometer for adjusting the limit value
- LCD with the QBM65.1...

Display, setting and connection elements

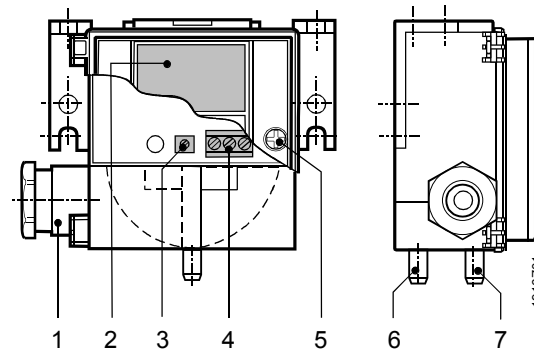

Legend

- 1 Cable entry gland Pg 11 with cable strain relief
- 2 Digital display for sensor signal in Pa (only with the **QBM65.1-...**)
- 3 Potentiometer, to set the measuring range (only with the **QBM65.2-...**); supplied in the fully clockwise position (100 % signal)
- 4 Terminal block
- 5 Safety screw for hinged cover
- 6 Nipple for tubing connection "+"
- 7 Nipple for tubing connection "-"

Engineering notes

The transformer used must be suited for safety extra-low voltage. It must have separate windings and be designed for 100 % duty.

It must be sized and fused in compliance with local safety regulations.

If the line length exceeds 50 m and runs parallel to mains cables, screened cable must be used!

Mounting and installation notes

The QBM65... is suitable for direct mounting on ducts, walls or ceilings and in control panels.

The sensor should be mounted vertically.

Where possible, the pressure connection nipples should be at the bottom, or if necessary, to the side, and they should always be higher than the duct probes. Horizontal mounting (with the hinged cover to the top or bottom) is **NOT RECOMMENDED**. If horizontal mounting cannot be avoided, account must be taken of deviations in the measured value (refer to "Factory calibration", below).

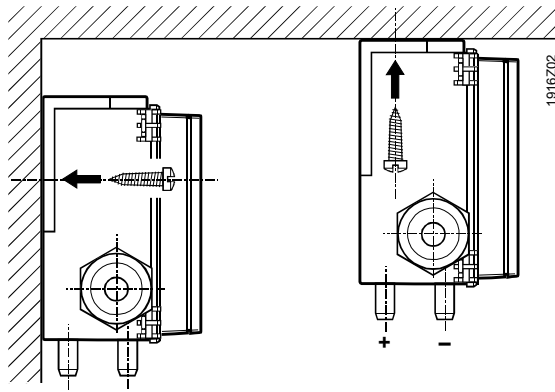

⚠ Caution:

If the pressure connection nipples face upward or are at a lower level than the duct probes, condensation can collect inside the unit, causing damage to the sensor.

When mounting on insulated air ducts, mounting bracket AQB21.1 is required. Snap-on connection between sensor and bracket.

A 2 m length of plastic tubing is supplied with the sensor and can be adapted to the duct probes on site.

The tubing with the higher pressure (lower vacuum) must be connected to nipple "P1" or "+", and the tubing with the lower pressure (higher vacuum) must be connected to nipple "P2" or "-".

The sensor is supplied with mounting instructions.

Factory calibration

The values given under "Technical data" are valid only when the differential pressure sensor is mounted vertically.

Should it be necessary to mount the sensor horizontally, i.e. with the hinged cover at the top or bottom (NOT RECOMMENDED), account must be taken of the deviations in the measured value.

Recommended orientation: hinged cover in vertical position. Signal: as per factory calibration (mandatory with the QBM65-1U)	NOT RECOMMENDED: Hinged cover facing downward. Signal: approximately 10 Pa above actual pressure	NOT RECOMMENDED: Hinged cover facing upward. Signal: approximately 10 Pa below actual pressure
---	---	---

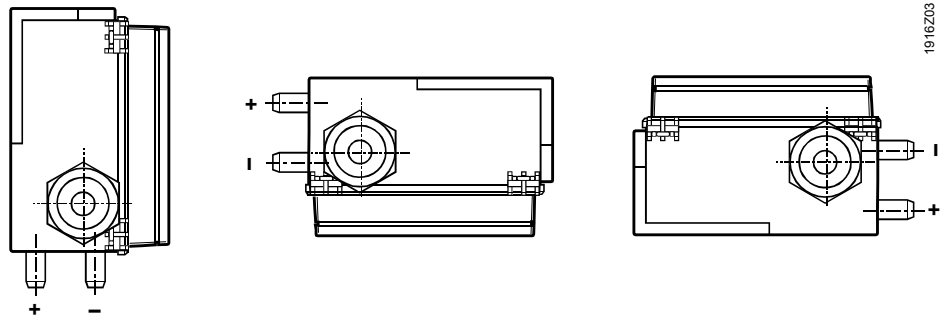

Technical data

Power supply	Operating voltage	AC 24 V ±15 % or DC 13.5...33 V
	Safety extra-low voltage SELV or Protection extra-low voltage PELV	HD384
	Frequency	50/60 Hz
	Power consumption	<0.5 VA
	Current consumption	<10 mA
Signal output	Output voltage	DC 0 ...10 V
	Load (R_{Last})	> 10 kΩ
	Output	not galvanically separated, 3-wire connection, short-circuit proof and protected against reversed polarity)
Functional data	Measuring range	refer to "Type summary"
	Measuring element	piezoresistive (Silicone diaphragm and ceramic lever)
	Measuring accuracy when mounted in recommended orientation and at an ambient temperature of 20 °C (FS = Full Scale)	
	• With linear characteristic	
	– Zero point	<±0.7 % FS
	– Total linearity and hysteresis	<±1 % FS
	– TC zero point	<±0.04 % FS/°C
	– TC sensitivity	<±0.02 % FS/°C
	For QBM65-1 and QBM65.1-1	
	– Zero point	<±1 % FS
– Total linearity and hysteresis	<±2 % FS	
– TC zero point	<±0.10 % FS/°C	
– TC sensitivity	<±0.05 % FS/°C	
For QBM65-1U		
– Total zero point, linearity, reproducibility and hysteresis	<±3 % 3 Pa (3 % FS)	
– TC zero point	<±0.10 % FS/°C typical	
– TC sensitivity	<±0.05 % FS/°C typical	
• With extracting-the-root characteristic		
– Absolute error (2...100 % of pressure range)	$\leq \pm 0.3 \sqrt{\frac{pFS}{p}} + 1.5$ [% of final value]	
– TC zero point (2...100 % of pressure range)	$< \pm 0.06 \sqrt{\frac{pFS}{p}}$ in % FS/°C	
– TC sensitivity	<±0.02 % FS/°C	
For QBM65.2-1		
– Absolute error (2...100 % of pressure range)	$\leq \pm 0.6 \sqrt{\frac{pFS}{p}} + 1.5$ [% of final value]	
– TC zero point (2...100 % of pressure range)	$< \pm 0.15 \sqrt{\frac{pFS}{p}}$ in % FS/°C	
– TC sensitivity	<±0.05 % FS/°C	
Response time	<10 ms	
Pressure ranges	refer to "Type summary"	
Max. perm. pressure	refer to "Type summary"	
Bursting pressure	500 hPa/500 mbar	
Display (only with QBM65.1...) Range	liquid crystal standard pressure measuring range in Pa, 3.5 Digit	
Media	air and nonaggressive gases	
Perm. temperature of medium	0...70 °C	
Maintenance	no maintenance required	

Connection	Connection terminals	screw terminals for 2 × 1.5 mm ²
	Cable entry	Pg 11 cable gland
	Pressure connection	plastic nozzle 6.2 mm dia.
Protective data	Degree of protection	IP 54 to IEC 529
	Safety class	III to EN 60 730
Environmental conditions	Perm. ambient temperature	
	Operation	0...70 °C
	Storage/transport	-10...+70 °C
	Perm. ambient humidity	<90 % r.h., noncondensing
Standards		
Product standards	Automatic electric controls for household and similar use	EN 60 730-2-14
Electromagnetic compatibility	Emmissions to	EN 50 081-1
	Immunity to	EN 50 082-2
CE conformity to	EMV directive	89/336/EEC
C conformity to	Australian EMC Framework	Radio Communication Act 1992
	Radio Interference Emmission Standard	AS/NZS 3548
Approbation	UL standard	UL 3101-1 First Edition
	CSA standard	CSA C22.2 No. 1010.1-92
Fire safety	Fire class to	UL94
	Hinged cover	HB
	Pressure casing, complete	V-2
	Tubing	V-2
Materials	Housing	PC (Polycarbonate)
	Hinged cover	ABS
	Pressure casing	PC with 10 % fibre-glass
	Diaphragm	2-component silicone LSR and PC with 10 % fibreglass, free from gas emissions
	Tubing	PVC (Polyvinylchloride, soft)
Weight	Weight (including packaging), without indication	0.09 kg
	Weight (including packaging), with indication	0.10 kg

Connection terminals

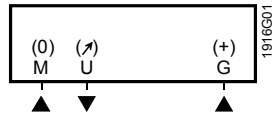

- G (+) Operating voltage AC 24 V or DC 13.5...33 V
- M (0) GND, measuring neutral
- U (↗) Measuring signal DC 0...10 V

Dimensions (all dimensions in mm)

