



Differential Pressure Sensors

QBM66...

for air or nonaggressive gases

- Pressure-linear characteristic with selectable pressure measuring range
- Operating voltage AC 24 V or DC 13.5...33 V
- Output signal DC 0...10 V
- Delivery with tubing connection set

Use

For acquiring the differential pressure of air or nonaggressive gases in ventilation, air conditioning and heating plant.

The differential pressure sensors are used to:

- Acquire over- or underpressure in air ducts in relation to ambient pressure
- Monitor filters and to control fans
- Acquire pressure differentials between different rooms

Type summary

Type reference	Measuring ranges		Overload ranges p_{\max}	Output signal
	Range 1	Range 2		
QBM66.201	0... 100 Pa	0... 200 Pa	$\pm 5,000$ Pa	DC 0...10 V
QBM66.202	0... 250 Pa	0... 500 Pa	$\pm 10,000$ Pa	DC 0...10 V
QBM66.203	0...1,500 Pa	0...3,000 Pa	$\pm 20,000$ Pa	DC 0...10 V

Accessories

Name	Type reference /part no.	Remark
Tubing connection set, consisting of: – 2 m PVC tube (inside dia. 5 mm, outside dia. 7 mm) – 2 air duct probes – 4 fixing screws	None	Included in standard delivery
Mounting bracket (5 pieces) for top hat rails to DIN, HT 35-7.5	AQB21.2	<u>Not</u> included in standard delivery
Air duct probe (for simple, quick and airtight mounting)	FK-PZ1	<u>Not</u> included in standard delivery
Air duct probe (with orifice plate for precise measurements)	FK-PZ2	(see data sheet N1589)

Ordering and delivery

When ordering, please give name and type reference, e.g. differential pressure sensor **QBM66.201**.

The differential pressure sensor is supplied complete with tubing connection set.

The sensor comes set for measuring range 2 (DIL switch in top position ) (refer to "Mode of operation" and "Mechanical design").

Equipment combinations



Any systems or devices capable of acquiring and handling the sensor's DC 0...10 V output signal.

Mode of operation

The sensor acquires the differential pressure with a silicon rubber diaphragm. The deflection of the diaphragm is sensed and converted to an electrical signal. A DIL switch is used to match the measuring range on an individual basis.



The sensor's electronic circuit generates a pressure-linear signal, which is calibrated and temperature-compensated.

It is delivered by the sensor as an analog DC 0...10 V output signal.

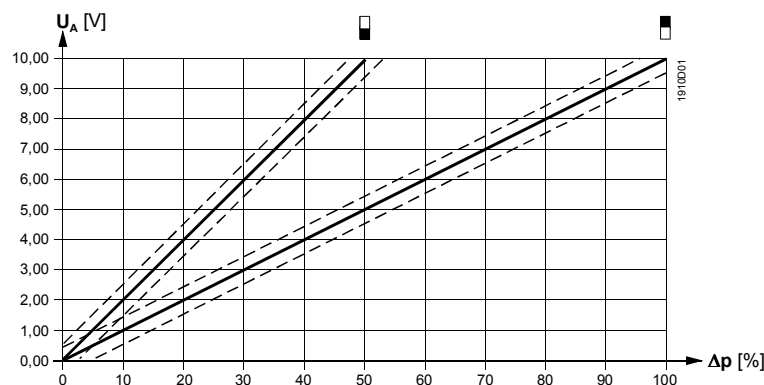
Sensor characteristics of measuring ranges 1 () and 2 ()



Legend

U_A Output voltage in V
 Δp Measuring range in percent
,  DIL switch positions

For detailed information on accuracy, refer to "Technical data".

Mechanical design



The differential pressure sensor is designed for wall or ceiling mounting. It consists of the following components:

- Sensor housing with mounting bracket, cable entry and removable snap-on cover with safety screw
- Pressure chamber with diaphragm and ceramic lever
- Printed circuit board with connection terminals and DIL switch for selecting the measuring range

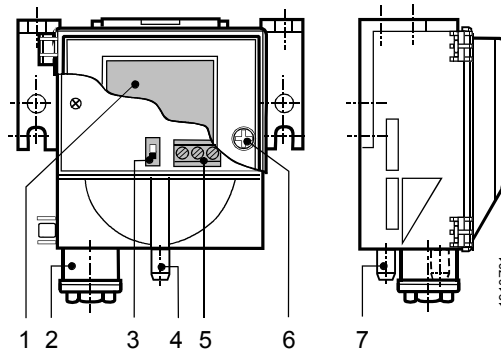
Display, setting and connection elements



Legend

- 1 Label with sensor characteristics for measuring ranges 1 and 2
- 2 Cable gland entry Pg 11 (without cable strain relief)
- 3 DIL switch for selecting the measuring range:
Measuring range 1 = bottom position 
Measuring range 2 = top position 
Factory-set calibration position = top 
- 4 Nipple for tubing connection (-), for the lower pressure side (higher vacuum)
- 5 Terminal block
- 6 Safety screw for hinged cover
- 7 Nipple for tubing connection (+) for the higher pressure side (lower vacuum)

For mounting on 35 x 7.5 top hat rails to DIN, the top hat rail adapter, which is available as an accessory item, can be used.

Engineering notes

The transformer used must be suited for safety extra low voltage (SELV); it must have separate windings and be designed for 100 % duty.

Transformers are to be sized and fused in compliance with local safety regulations.

The permissible cable lengths must be observed.

If cable lengths exceed 50 meters and run parallel to mains cables, shielded cable should be used!

Mounting notes

The differential pressure sensor is suited for direct mounting on air ducts, walls or ceilings and in control panels.

The sensor should be mounted vertically.

To ensure the degree of housing protection specified in "Technical data", the pressure connecting nipples must be pointing downward and should always be located higher than the air duct probes.

Horizontal mounting (with the hinged cover at the top or bottom) IS NOT RECOMMENDED. If horizontal mounting is a requirement, measured value deviations must be taken into consideration (refer to "Factory calibration" below).

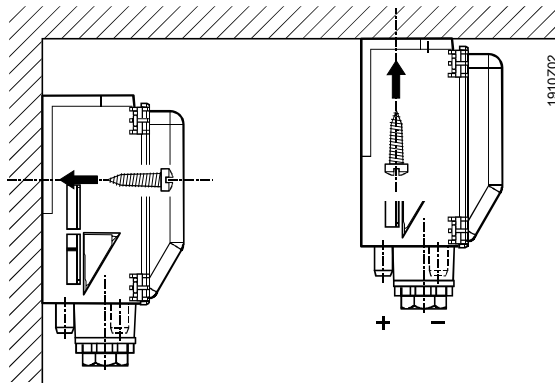

⚠ Caution:
 If the pressure connection nipples point upward or are at a lower level than the air duct probes, condensation can collect inside the sensor, causing damage to the device.

When mounting on 35 x 7.5 top hat rails to DIN, mounting bracket AQB21.2 is required (available as an accessory item). The sensor snaps on the bracket.

A 2 m length of plastic tubing is supplied with the sensor and can be adapted to the duct probes on site.

The tubing with the higher pressure (lower vacuum) must be connected to nipple "P1" or "+" while the tubing with the lower pressure (higher vacuum) must be connected to nipple "P2" or "-".

The sensor is supplied with mounting instructions.

Factory calibration

The values specified in "Technical data" are valid only if the sensor is mounted vertically.

Should it be necessary to mount the sensor horizontally (with the hinged cover at the top or bottom, NOT RECOMMENDED), measured value deviations must be taken into account.

Recommended orientation: Hinged cover in vertical position.
 Signal: As per factory calibration

NOT RECOMMENDED:
 Hinged cover facing downward.
 Signal: Approximately 12 Pa higher than the effective pressure

NOT RECOMMENDED:
 Hinged cover facing upward.
 Signal: Approximately 12 Pa lower than the effective pressure

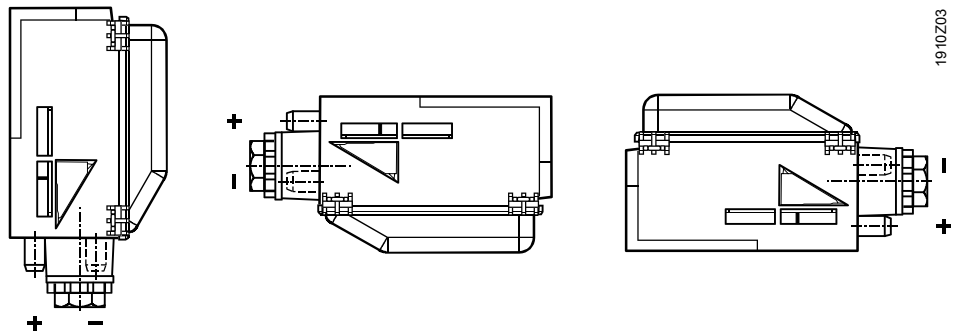

Technical data

Power supply	Operating voltage	AC 24 V \pm 20 % or DC 13.5...33 V
	Safety extra low-voltage (SELV) or protective extra low-voltage (PELV)	HD384
	Frequency	50/60 Hz
	Power consumption	< 0.5 VA
	Current draw	< 15 mA at DC 33 V
Signal output	Output voltage	DC 0 ...10 V
	Burden (R_{Last})	> 10 k Ω
	Output	not galvanically separated, 3-wire connection, short-circuit-proof and protected against reversed polarity

Functional data	Measuring range	see "Type summary"
	Sensing element	piezoresistive (silicon rubber diaphragm and ceramic lever)
	Measuring accuracy when mounted in the recommended position, measuring range 2 (100 %), and at an ambient temperature of 20 °C (FS = Full Scale)	
	Total error	<±3 % FS
	TC zero point	<±0.1 % FS / °C
	TC sensitivity	<±0.05 % FS / °C
	Time constant t_{63}	<1 s
	Pressure measuring range	refer to "Type summary"
	Max. permission pressure	refer to "Type summary"
	Bursting limit	500 hPa / 500 mbar
	Media	air and nonaggressive gases
	Perm. temperature of medium	0...70 °C
	Maintenance	maintenance-free
Connections	Electrical connections	
	Screw terminals for Cable entry	max. 2 × 1.5 mm ² cable entry gland Pg 11 (without strain relief)
	Pressure connections	plastic nozzles 6.2 mm dia.
Protective data	Degree of protection when mounted in the recommended position	IP 42 to IEC 529
	Safety class	III to EN 60 730
Environmental conditions	Operation to	IEC 721-3-3
	Climatic conditions	class 3K5
	Temperature	-5...+70 °C
	Humidity	<95 % r. h. (noncondensing)
	Mechanical conditions	class 3M2
	Transport/storage to	IEC 721-3-2
Climatic conditions	class 2K3	
Temperature	-25...+70 °C	
Humidity	<95 % r. h. (noncondensing)	
Mechanical conditions	class 2M2	
Norms and standards	Product safety	Automatic electrical controls for household and similar use EN 60 730-1
	Electromagnetic compatibility	Immunity to EN 50 082-1 Emissions to EN 50 081-1
CE conformity	EMC directive	89/336/EEC
	Low-voltage directive	73/23/EEC
✓ conformity	Australian EMC Framework	Radio Communication Act 1992
	Radio Interference Emission Standard	AS/NZS 3548
Fire safety	Fire class to	UL94
	Hinged cover	HB
	Pressure chamber (complete)	V-0
	Plastic tubing	V-2
	Air duct probe	HB
Materials	Housing	PC (Polycarbonate)
	Hinged cover	ABS
	Pressure chamber	PC with 10 % glassfiber
	Diaphragm with disk	silicon and PA66 ±GF 25 %
	Plastic tubing	PVC (Polyvinylchloride, soft)
	Air duct probe	ABS
Weight	Weight (incl. packaging)	0.183 kg

Connection terminals

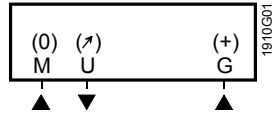

G (+) Operating voltage AC 24 V or DC 13.5...33 V
 M (0) GND, measuring neutral
 U (1) Measuring signal DC 0...10 V

Dimensions

QBM66...

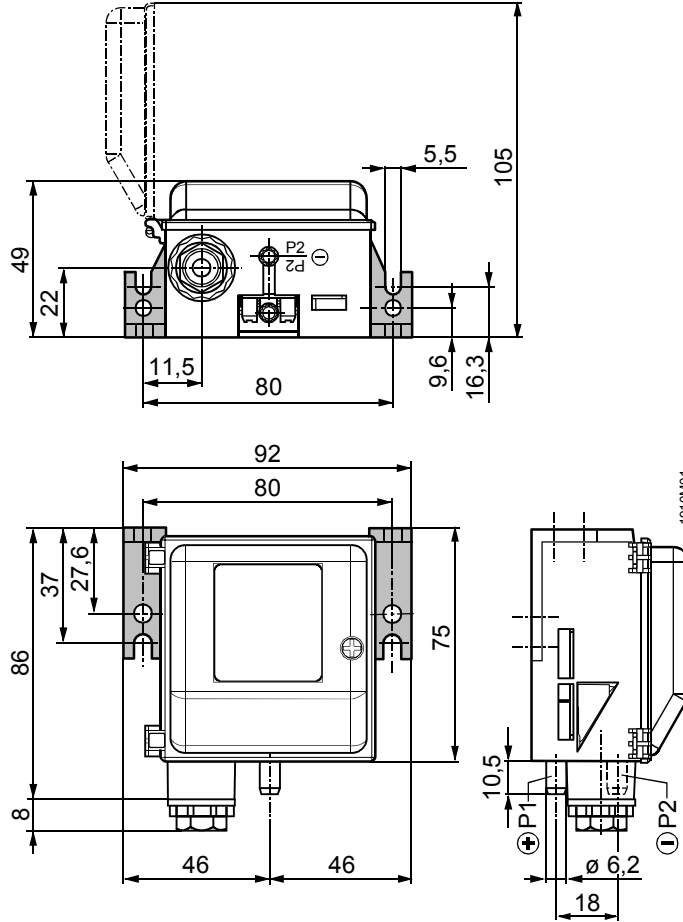

Air duct probe (ABS)

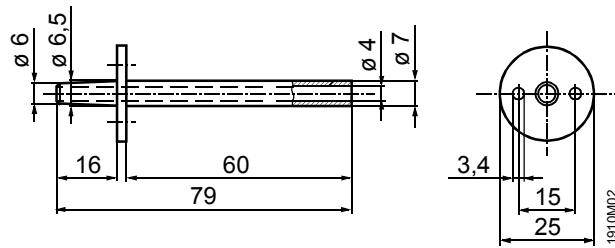

Bracket for top hat rail
AQB21.2

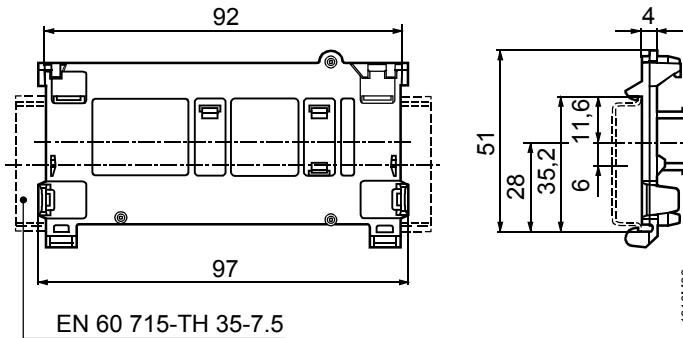

Dimensions in mm