



Double thermostat

Control Thermostat / Thermal Reset Limit Thermostat

RAZ-TW....

Combination of electromechanical TR and TW

- 2-position control thermostat and thermal reset limit thermostat with single-pole changeover microswitches
- Switching capacity of microswitches:
 - contact connection 1-2 16 (2.5) A, AC 250 V
 - contact connection 1-4 6 (2.5) A, AC 250 V
- Time constant conforming to DIN EN 14597
- Push-in¹ terminals for fast wiring
- 2 mounting choices: pocket or wall mounting
- External setting knob for setpoint adjustment
- Internal adjustment of the switch-off temperature

Use

Typical applications:

- Heat generation plant
- For general use in heating, ventilation and air conditioning plant

Function

When the adjustable setpoint of the control thermostat (RAZ-TR..) is reached on rising temperature, contact connection 1-2 changes over to contact connection 1-4. When the

temperature of the medium falls by the value of the switching differential, the control thermostat reverts to contact connection 1-2.

When the internally adjusted switch-off temperature of the thermal reset limit thermostat (RAZ-TW..) is reached, contact connection 1-2 changes over to contact connection 1-4. When the temperature of the medium falls by the value of the switching differential, the thermal reset limit thermostat (RAZ-TW..) reverts to contact connection 1-2.

Type summary

Product number	Stock number	Control and temperature range	Capillary tube length	Scope of delivery
RAZ-TW.1000P-J	S55700-P140	(TR) 15...95 °C (TW) 15...95 °C	700 mm	Double pocket for 2 sensing elements, 100mm length
RAZ-TW.1200P-J	S55700-P141	(TR) 40...120 °C (TW) 40...120 °C	700 mm	(ALT-DB100J , brass nickel-plated, PN10), cable gland M20 x 1.5 mm Mounting instructions

Accessories

Refer to Data Sheets N1193 and for protection pockets N1194.

Important: Double pocket **(ALT-DB..J)** with the ending „J“ fits to this RAZ units only.

Ordering

When ordering, please give type reference according to “Type summary“ (standard set).

If the accessories required are not those included in the standard set, they can be ordered separately according to the type reference given in Data Sheets N1193 and N1194.

Mechanical design

Double housing

The base of the thermostat is made of PA (reinforced) and is designed for pocket or wall mounting; the electromechanical control thermostat (TR) and the thermal reset limit thermostat (TW) use 2 separate capillary type sensing elements.

The cover is made of PA and accommodates the setpoint setting knob plus the viewing window.

The cable gland is M20 x 1.5 mm.

Notes

Mounting aid

Installation Instructions are enclosed in the package.

Mounting location

It must be ensured that there is sufficient clearance above the thermostat for adjusting the setpoint and for removing or replacing the thermostat, if required.

Pocket mounting

Mount the pocket and adjust the hexagon as required. Immerse the capillary sensing element in the pocket and secure the base to the pocket by means of the screw.

Wall mounting with sensing element in the pocket

To prepare for wall mounting, knock out the fixing holes in the housing and pull out the capillary tube until the required length is reached. After immersing the capillary sensing elements in the pocket, secure it with a clamp (mounting accessories).

Temperature setting

The internal limit temperature must be adjusted only by qualified personnel.

Wiring

The appliance must be wired by the installer only.

The cables used must meet the insulation requirements for mains voltage.

Wire the thermostat according to the connection diagram and in compliance with local regulations.

Max. AC 250 V

Caution: prior to opening the housing, disconnect the thermostat from the mains supply.

Earth connections must be made in compliance with the regulations.

Disposal



The device is a waste electronic equipment in terms of the European Directive 2002/96/EC (WEEE) and should not be disposed as part of unsorted municipal waste. The relevant national legal rules are to be paid attention. Use for disposal the systems set up to collect electronic waste. Observe all local and applicable laws.

Technical data

Switching mechanism of TR and TW	Switching capacity		
	Nominal voltage	AC 24...250 V	
	Nominal current $I_{(M)}$	contact connection 1-2	0.1...16 (2.5) A
		contact connection 1-4	0.1... 6 (2.5) A
	External fuse	16 A	
	Life expectancy at nominal rating	TR contact	min. 250 000 switching cycles
		TW contact	min. 100 000 switching cycles
	Safety class	I to EN 60 730	
	Degree of protection:	IP 40 to EN 60 529	
	Norms and Standards	Temperature range RAZ-TW.1000P-J	
Externally adjustable control temperature (TR)		15...95 °C	
Internally adjustable switch-off temperature (TW)		15...95 °C (with tool)	
Temperature range RAZ-TW.1200P-J			
Externally adjustable control temperature (TR)		40...120 °C	
Internally adjustable switch-off temperature (TW)		40...120 °C (with tool)	
Thermal switching differential TR and TW		6 K (range dependent)	
CE conformity, directives			
Electromagnetic compatibility in accordance		2004/108/EG	
Low voltage directive		2004/95/EG	
Pressure equipment directive	97/23/EEC (CE 0497)		
ENEC (European Norms Electrical Certification)			
C-tick	 N474		
DIN EN 14597	TW 119708		
Product standards			
Automatic electrical controls for household and similar use	EN 60 730-1		
Special requirements placed on temperature-dependent controls			
Type 2 TR action	EN 60 730-2-9		
Type 2 TW action	BL (EN 60 730-1/2-9) EN 14597 BLFHKLNPV (EN 60 730-1/2-9) EN 14597		
Radio interference protection	click rate $N \leq 5$ to EN 55 014		
Environmental conditions	Operation		
	class 3K5 to IEC 60 721-3-3		
	Max. temperature on bulb		
	RAZ-TW.1000P-J	max. switch-off temperature +25 K	
	RAZ-TW.1200P-J	max. switch-off temperature +25 K	
	Ambient temperature at the housing	max. 80 °C (T80)	
	Humidity	< 95 % r.h.	
	Mechanism	class 3M2 to IEC 60 721-3-3	
	Storage and transport		
	class 2K3 to IEC 60 721-3-2		
Ambient temperature	-25...+70 °C		
Humidity	< 95 % r.h.		
Max. temperature socket	125 °C		
Degree of pollution	2 normal to EN 60 730		
Controlled medium	Water, oil and air		
Influence of the ambient temperature	-0.18 °C/°C		

Calibration	Manufacturing deviation TR and TW	$\pm 3\text{ }^{\circ}\text{C}$
	Drift after life expectancy TR and TW	$< \pm 5\text{ }%$
	Calibrated for ambient temperature at the switching mechanism and capillary tube	22 $^{\circ}\text{C}$ to DIN 14597
	Time constant in: water	$< 45\text{ s}$ to DIN 14597
	oil	$< 60\text{ s}$ to DIN 14597
	air	$< 120\text{ s}$ to DIN 14597
Connections	Electrical connections	Push-in ¹ terminals for wires 6 x 0.75...2.5 mm ²
	Earth connection	Push-in ¹ terminals for wires 2 x 0.75...2.5 mm ²
	Cable entry gland	M20 x 1.5 mm
	External wiring flexible cord	Type M attachment (designed to be connected with prepared conductors, e.g. ferrules)
General data	Housing colors	base RAL 7001 (dark-grey) cover RAL 7035 (light-grey)
	Dimensions of sensing elements TR and TW	6.5 mm dia. x 85 mm / 6.5 mm dia. x 76 mm
	Capillary length	700 mm
	Min. bending radius of capillary	R min. = 5 mm
	Construction	
	Carrier of switching mechanism	plastic
Capillary tube and sensing elements	copper	
Diaphragms	stainless steel	
	Weight of standard set	0.53 kg

Connection diagram

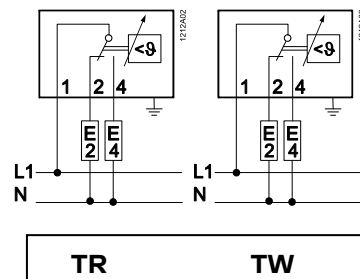

TR/TW:
Contact 1-2 closed = Normal mode

TR/TW:
Contact 1-4 closed = Switch-off temperature

¹⁾ "Push In" is a patented connection technique developed by Weidmüller, Germany's leading manufacturer of electrical connection technology

Dimensions

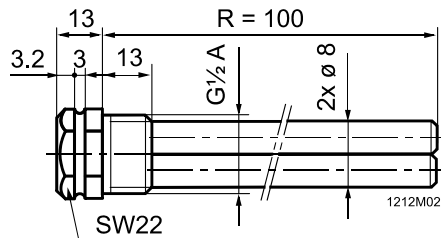
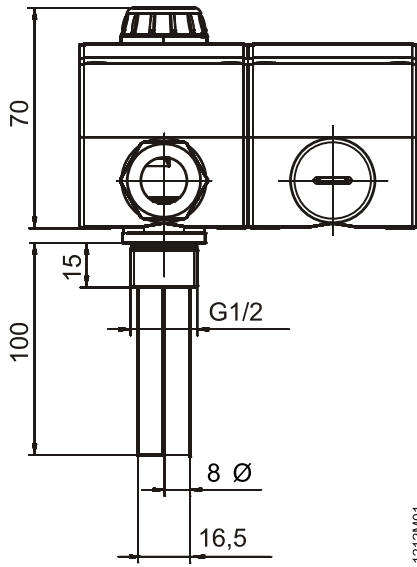
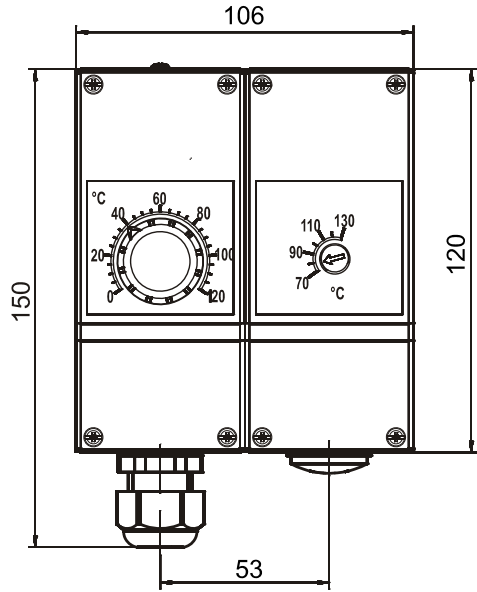

ALT-DB...J