



ACVATIX™

Electromotoric actuators

SQL321B..
SQL361B..

For VKF42.. butterfly valves

-
- **SQL321B..** Operating voltage AC 220 V, 2-position (SPDT) control signal
 - **SQL361B..** Operating voltage AC 220 V, DC 0...10 V control signal
 - **Optional 1000 Ω potentiometer and auxiliary switch**
 - **Nominal angle of rotation 90°**
 - **Handwheel and position indicator**
 - **Built-in heating element to avoid condensation**
 - **Compatible with EN ISO 5211 flanges**

Use

For operation of VKF42.. butterfly valves as shutoff and control valves in heating, ventilation and air conditioning plants.

Type summary

Product No.	Stock No.	Operating Voltage	Positioning Signal	Position Feedback Signal	Positioning Time for 90° at 50 Hz [s]	Nominal Torque [Nm]	Flange Connection EN ISO 5211
SQL321B25	S55164-A100	AC 220 V	2-position (SPDT)	-	11	25	F07
SQL321B50	S55164-A101	AC 220 V	2-position (SPDT)	-	19	50	F07
SQL361B50	S55164-A102	AC 220 V	DC 0...10 V	DC 0...10 V	19	50	F07
SQL321B150	S55164-A103	AC 220 V	2-position (SPDT)	-	39	150	F07
SQL361B150	S55164-A104	AC 220 V	DC 0...10 V	DC 0...10 V	39	150	F07
SQL321B270	S55164-A105	AC 220 V	2-position (SPDT)	-	39	270	F10
SQL361B270	S55164-A106	AC 220 V	DC 0...10 V	DC 0...10 V	39	270	F10
SQL321B570	S55164-A107	AC 220 V	2-position (SPDT)	-	47	570	F12
SQL361B570	S55164-A108	AC 220 V	DC 0...10 V	DC 0...10 V	47	570	F12
SQL321B1400	S55164-A109	AC 220 V	2-position (SPDT)	-	76	1400	F14
SQL361B1400	S55164-A110	AC 220 V	DC 0...10 V	DC 0...10 V	76	1400	F14
SQL321B2650	S55164-A111	AC 220 V	2-position (SPDT)	-	105	2650	F16
SQL361B2650	S55164-A112	AC 220 V	DC 0...10 V	DC 0...10 V	105	2650	F16

Ordering

The actuator, butterfly valve and any accessories must be ordered separately.
When ordering, please specify the quantity, product name and product number.

Example

Product No.	Stock No.	Description	Quantity
SQL361B150	S55164-A104	Electromotoric actuator	1
ASC10.21	S55845-Z122	Double auxiliary switch	1

Delivery

The actuator, accessory and butterfly valve are packed separately and delivered as individual items.

Rev. No.

Please see chapter "Rev. No" on page 12.

Equipment combinations

Butterfly Valve	Electromotoric Actuators ¹⁾						
	SQL321B25 SQL361B50	SQL321B50 SQL361B50	SQL321B150 SQL361B150	SQL321B270 SQL361B270	SQL321B570 SQL361B570	SQL321B1400 SQL361B1400	SQL321B2650 SQL361B2650
	Δp_s [kPa]						
VKF42.50	700						
VKF42.65	700						
VKF42.80	700						
VKF42.100	700						
VKF42.125		700					
VKF42.150			700				
VKF42.200			700				
VKF42.250				700			
VKF42.300					700		
VKF42.350					700		
VKF42.400						700	
VKF42.450						700	
VKF42.500							700
VKF42.600							700

¹⁾ SQL321B..., SQL361B... electromotoric actuators can be mounted directly on VKF42.. butterfly valves.

Δp_s Maximum permissible differential pressure at which the motorized butterfly valve will close securely against the pressure (close off pressure)

Mechanical design

The actuator is driven by a 2-position (SPDT) or DC 0...10 V control signal from the controller and generates a rotary motion which is transferred to the butterfly valve via a driver.

These electromotoric actuators require no maintenance. They have a reversible asynchronous motor which drives the main shaft via gear train, which accommodates the diagonal square head of the butterfly valve. For SQL321B25, the coil spring is fitted with handwheel shaft, handwheel is engaged when pushed in. For others, the worm shaft is fitted with a direct-acting handwheel.

The actuators are 90° rotated so as to work with Siemens VKF42.. butterfly valves. During automatic operation, rotation is stopped by two built-in end-switches.

To prevent the temperature inside the housing from falling below the dew point temperature, the actuators are equipped with a built-in heating element.

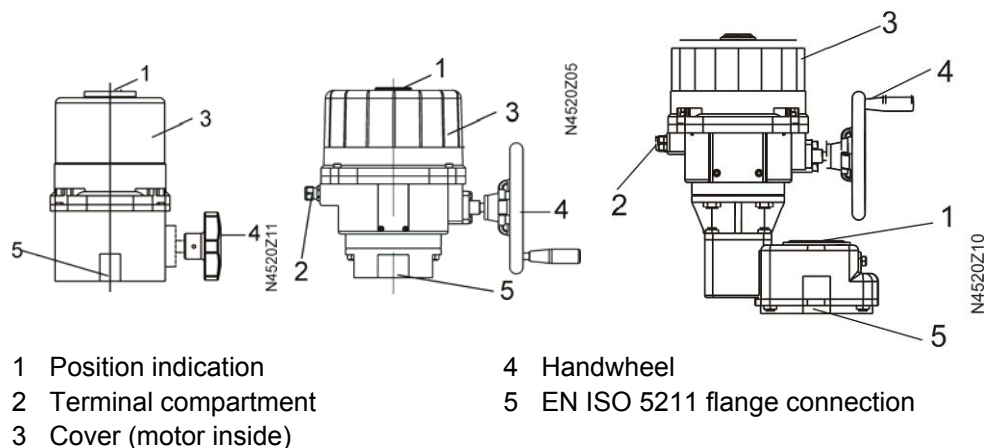





Calibration
SQL361B..

In order to determine the disc position fully closed “0%” or fully open “100%”, calibration is recommended on initial commissioning of modulating type actuator.

Prerequisites

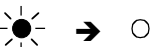
- Actuator is mounted on butterfly valve
- Rotate the actuator to the half-open position using the handwheel
- Housing cover is removed

Step	To do	LED on PCB		Actuator action
1. Power supply	<ul style="list-style-type: none"> • Supply power to actuator terminal 1 and 2 • No control signal connected 		Lit	Actuator moves to “0%” (closed) disc position
2. Start calibration	<ul style="list-style-type: none"> • Press button S2 for 5 seconds 		Dark	Actuator remains at “0%” (closed) disc position
3. 0% (close) position	<ul style="list-style-type: none"> • Press button S6 • 0% (closed) value is stored 		Lit → Dark	When S6 is released actuator moves to 100% (open) disc position
	<ul style="list-style-type: none"> • Wait, actuator moves to open disc position 			
4. 100% (open) position	<ul style="list-style-type: none"> • Press button S7 • 100% (open) value is stored 		Lit	When S7 is released actuator moves to “0%” (closed) disc position
	<ul style="list-style-type: none"> • Wait, actuator moves to close disc position 			
5. Calibration completed	<ul style="list-style-type: none"> • Press button S6 • Calibration is now completed 		Flash	Actuator remains at “0%” (closed) disc position

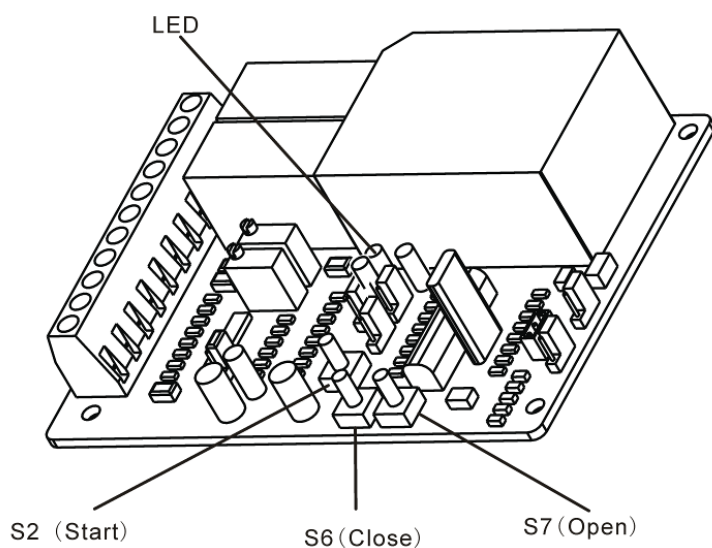

Normal operation

Actuator follows control signal Y, the LED on PCB lights.

Accessories

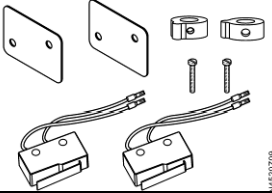
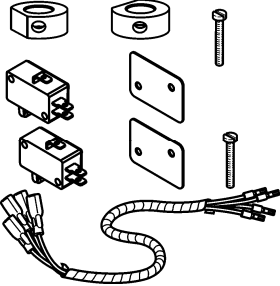
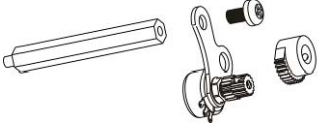
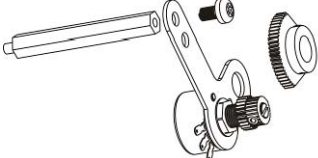
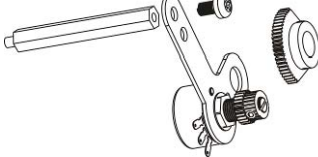
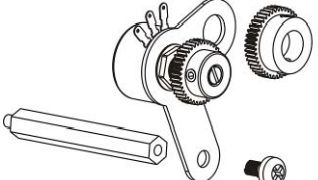
Product No.	Stock No.	Figure	Description	For Actuators
ASC10.20	S55845-Z121		Double auxiliary switch	SQL321B25
ASC10.21	S55845-Z122		Double auxiliary switch	SQL321B50 SQL361B50 SQL321B150 SQL361B150 SQL321B270 SQL361B270 SQL321B570 SQL361B570 SQL321B1400 SQL361B1400 SQL321B2650 SQL361B2650
ASZ10.20	S55845-Z123		Potentiometer 1000 Ω	SQL321B25
ASZ10.21	S55845-Z124		Potentiometer 1000 Ω	SQL321B50 SQL321B150
ASZ10.22	S55845-Z125		Potentiometer 1000 Ω	SQL321B270 SQL321B570
ASZ10.23	S55845-Z126		Potentiometer 1000 Ω	SQL321B1400 SQL321B2650

Engineering notes

Electrical installation

The actuators must be electrically connected in accordance with local regulations and with the connection diagrams.

Warning



Regulations and requirements to ensure the safety of people and property must be always observed.

Mounting notes

Mounting instructions

Product No.	Documentation No.
VKF42..	74 319 0808 0 (M4119)
SQL321B.. / SQL361B..	74 319 0809 0 (M4520)
ASC10..	74 319 0810 0 (M4520.1)
ASZ10..	74 319 0811 0 (M4520.2)

SQL321B.., SQL361B..

These actuators can be mounted directly on type VKF42.. butterfly valves. The butterfly valves have to be closed "0%" when the actuators are mounted onto the valves.

Orientation

The valve and actuator can be assembled on site. There is no need for special tools.

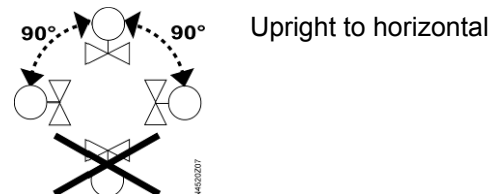

Commissioning notes

When commissioning the motorized butterfly valves, always check wiring and test the functions. This also applies to any additional components fitted, e.g. auxiliary switch.

Warning



To avoid pressure shocks on the butterfly valve, the VKF42.. must be driven to its fully open position either manually or via positioning signal prior to activating the pump(s).

The flow rate can be adjusted either by operating the electric actuators when necessary, or by operating the handwheel.

Operating notes

Manual operation mode

SQL321B25	Handwheel is engaged by pushing the handwheel in.
SQL321B50...B2650 SQL361B50...B2650	The handwheel is always engaged.

Reversing the direction of rotation

If the direction of rotation needs to be reversed, simply exchange the connections Y12 and Y14.

Setting the angle of rotation

The 0...90° angle of rotation for the mechanical limit switches is factory-set and cannot be changed.

The potential-free auxiliary switches are equipped with adjustable switching points.

Maintenance notes

Warning



The actuators and butterfly valves require no maintenance.

Before performing any service work on the valve or actuator:

- Switch off the pump and power supply
- Close the main shut-off valves in the pipe work
- Release pressure in the pipes and allow them to cool down completely

If necessary, disconnect electrical connections from terminals.

The valve must be re-commissioned only with the handwheel or the actuator correctly assembled.

Disposal

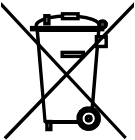

The products contain electrical and electronic components and must not be disposed of together with domestic waste. This applies in particular to the printed circuit board.

Legislation may demand special handling of certain components, or it may be sensible from an ecological point of view.

Observe all local and currently valid legislation.

Warranty

The engineering data specified in chapter "Equipment combinations" (page 2) are only guaranteed in connection with the Siemens butterfly valves listed.

Note

When using the actuators in connection with butterfly valves of other manufacture, correct functioning must be ensured by the user, and Siemens will assume no responsibility.

Technical data

		SQL321B25	SQL321B50	SQL321B150	SQL321B270	SQL321B570	SQL321B1400	SQL321B2650
		-	SQL361B50	SQL361B150	SQL361B270	SQL361B570	SQL361B1400	SQL361B2650
Power supply	Operating voltage	AC 220 V / 1 phase						
	Voltage tolerance	+/- 10%						
	Frequency	50 / 60 Hz						
	Power consumption ¹⁾	42 VA	88 VA	91 VA	165 VA	194 VA	361 VA	436 VA
Signal inputs	Positioning signal SQL321.. SQL361..	2-position (SPDT) DC 0...10 V						
	Parallel operation	For SQL321B..., it is not possible for electrical parallel operation of several actuators. For SQL361B..., electrical parallel operation of several actuators is possible, and the specific quantity of actuator depends on the controller output.						
	Position feedback SQL361..	DC 0...10 V						
Operating data	Positioning time for 90° at 50 Hz	11 s	19 s	39 s	39 s	47 s	76 s	105 s
	Angle of rotation	90° ± 1° (factory setting)						
	Nominal Torque ¹⁾	25 Nm	50 Nm	150 Nm	270 Nm	570 Nm	1400 Nm	2650 Nm
Auxiliary switch	Switching capacity	AC 250 V, 5 A resistive	AC 250 V, 10 A resistive					
	Heating element (Build in)	220 V 2.0 W	220 V 7.5 W	220 V 8.5 W				
Degree of protection Standards	Max. permissible medium temperature	-10...80 °C						
	Housing upright to horizontal	IP65 as per EN 60529						
	Insulation class	Class I as per EN 60730						
	CE-conformity As per EMC directive	2004/108/EC						
	Immunity	EN 61000-6-2:[2005] Industrial						
	Emissions	EN 61000-6-3:[2007] Residential						
	Electrical safety	EN 60730-1:[2000] +A1:[2004] +A2:[2008] +A12:[2003] +A13:[2004] +A14:[2005] +A16:[2007]						
	Low-voltage directive (LVD) AC 220 V	EN 60730-1:[2000] +A1:[2004] +A2:[2008] +A12:[2003] +A13:[2004] +A14:[2005] +A16:[2007] EN 60730-2-14:[1997] +A1:[2001] +A11:[2005] +A2:[2008]						
	C-tick	N474						
	Environmental compatibility	ISO 9001 (quality) Directive 2002/95/EC (RoHS)						
Dimension weight	Flange / shaft connection types to valve (top flange)	F07			F10	F12	F14	F16
	Dimensions	see "Dimensions", page 11, 12						
	Weight	see "Dimensions", page 11, 12						
Materials	Cable glands	2 x Pg 13.5		2 x Pg 16				
	Housing base, yoke	Die-cast aluminum alloy					Housing: Die-cast aluminum alloy Gear box: Cast Iron	
	Cover	Die-cast aluminum alloy						

¹⁾ These values apply at nominal voltage, ambient temperature of 20 °C and at nominal running time.

General ambient conditions

	Operation EN 60721-3-4	Transport EN 60721-3-2	Storage EN 60721-3-1
Environmental conditions	Class 4K1	Class 2K2	Class 1K3
Temperature	-20...65 °C	-30...65 °C	-5...55 °C
Humidity	15...100% r. h.	<95% r. h.	0...95% r. h.

Internal diagrams

SQL321B..

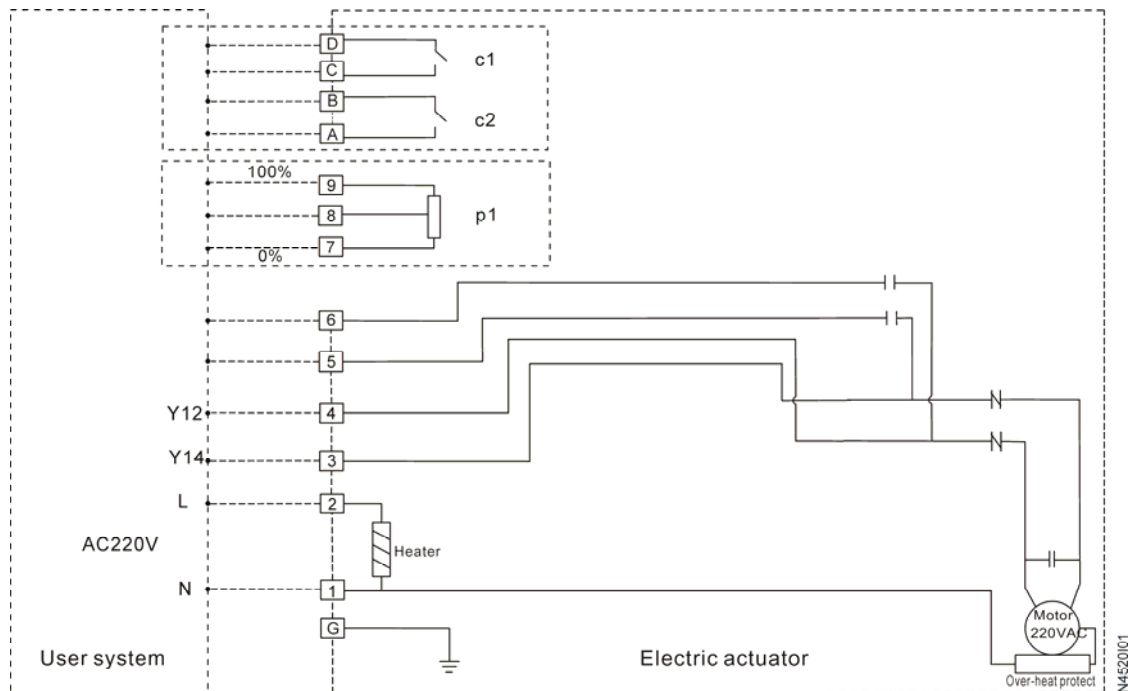

- L System potential AC 220 V
- N System neutral
- Y12 Positioning signal (Closed)
- Y14 Positioning signal (Open)
- c1 Auxiliary dry contact switch CLOSED (ASC10.20/ASC10.21)
- c2 Auxiliary dry contact switch OPEN (ASC10.20/ASC10.21)
- p1 Potentiometer (ASZ10..)

SQL361B..

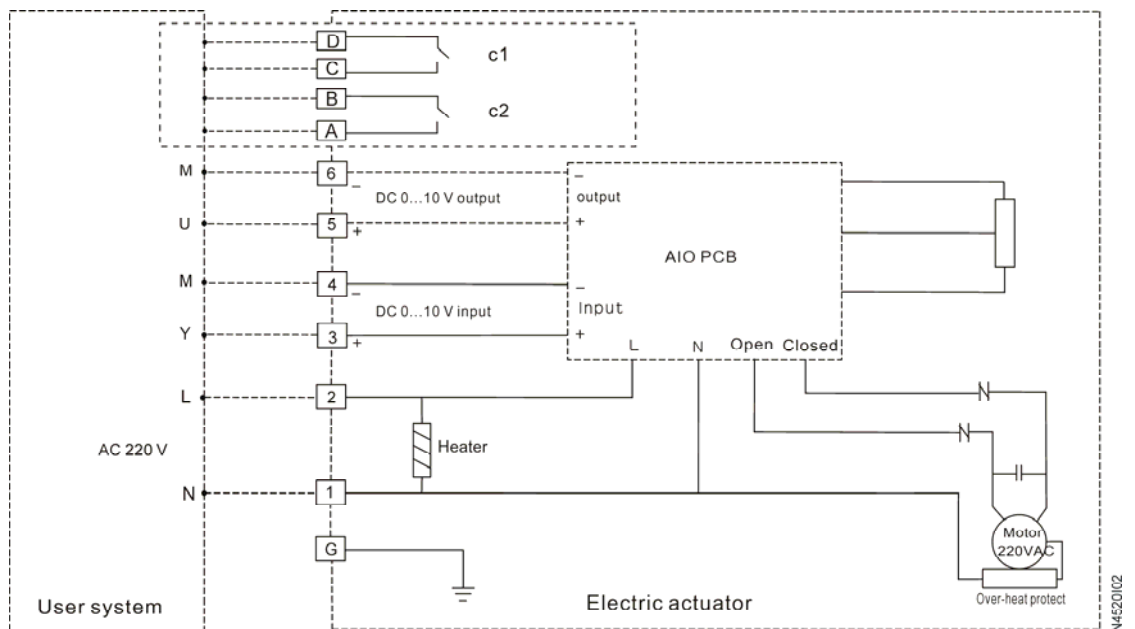

- L System potential AC 220 V
- N System neutral
- Y Positioning signal for DC 0...10 V
- M Measuring neutral
- c1 Auxiliary dry contact switch CLOSED (ASC10.20/ASC10.21)
- c2 Auxiliary dry contact switch OPEN (ASC10.20/ASC10.21)
- U Position feedback signal DC 0...10 V

Connection diagrams

SQL321B..

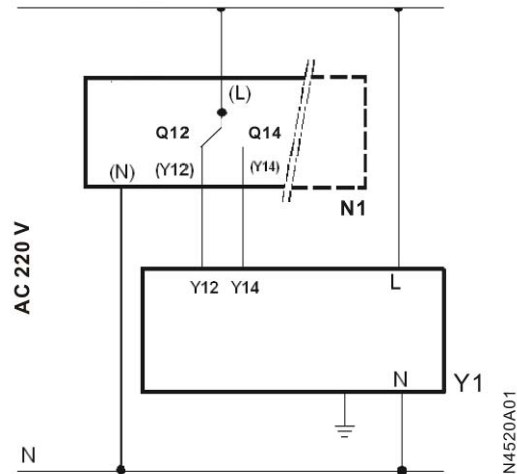

- N1** Controller
- Y1** Actuator
- L** 1 phase AC 220 V
- N** Neutral
- Q1, Q2** Controller contacts
- Y12** Positioning signal (Closed)
- Y14** Positioning signal (Open)

SQL361B..

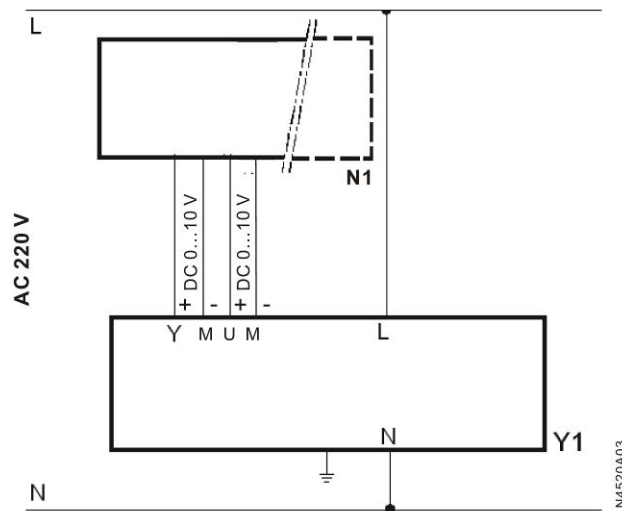

- N1** Controller
- Y1** Actuator
- L** 1 phase AC 220 V
- N** Neutral
- Y** Positioning signal DC 0...10 V
- M** Measuring neutral
- U** Position feedback signal DC 0...10 V

Dimensions (mm)

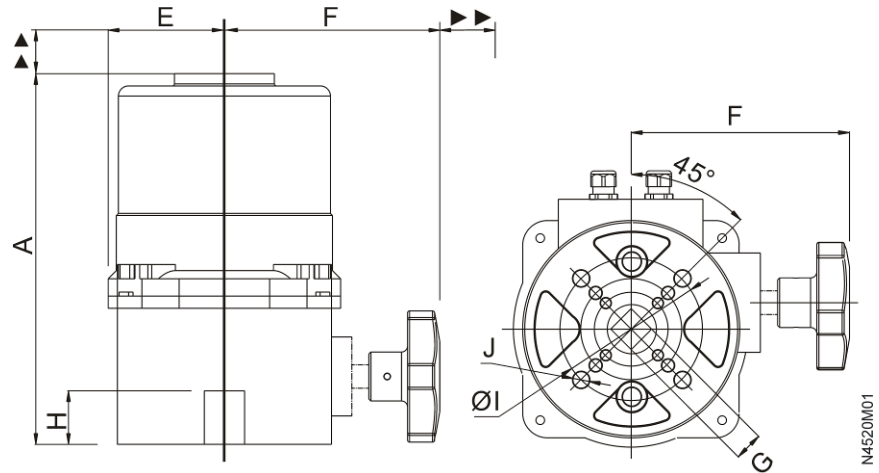

Product No.	A	E	F	H	G	Ø I	J	Weight [kg]	EN ISO 5211
SQL321B25	195	60	110	15	11	70	4-M8	3.6	F07

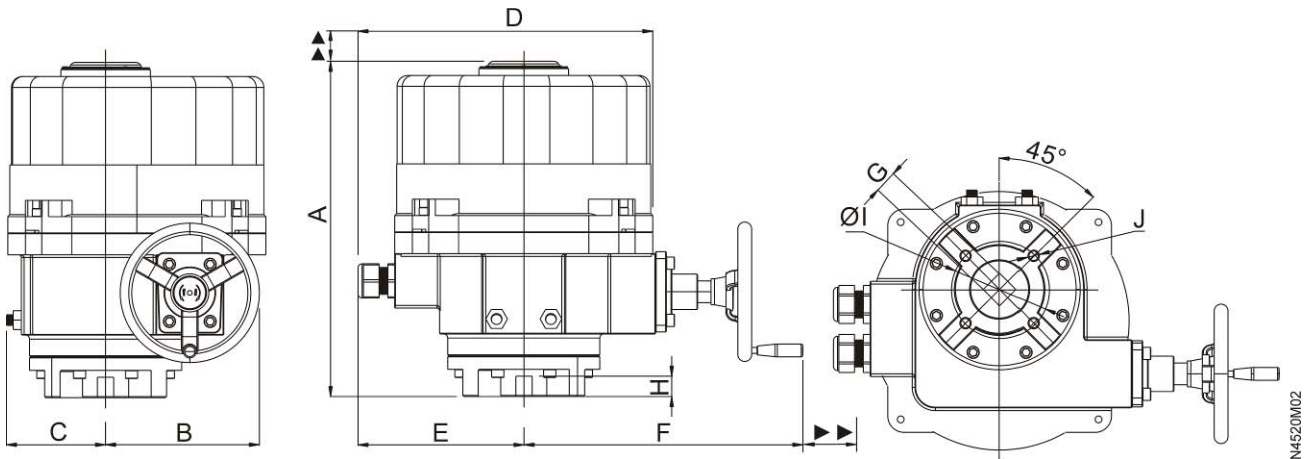

Product No.	A	B	C	D	E	F	G	H	Ø I	J	Weight [kg]	EN ISO 5211
SQL321B50	264	125	72	213	125	239	17*	35	70	4-M8	11	F07
SQL361B50							17					
SQL321B150	264	125	72	213	125	239	22	55	102	4-M10	22	F10
SQL361B150												
SQL321B270	336	154	98	377	148	251	27	55	125	4-M12	22	F12
SQL361B270												

* Actuator SQL361B50 has one additional bush.

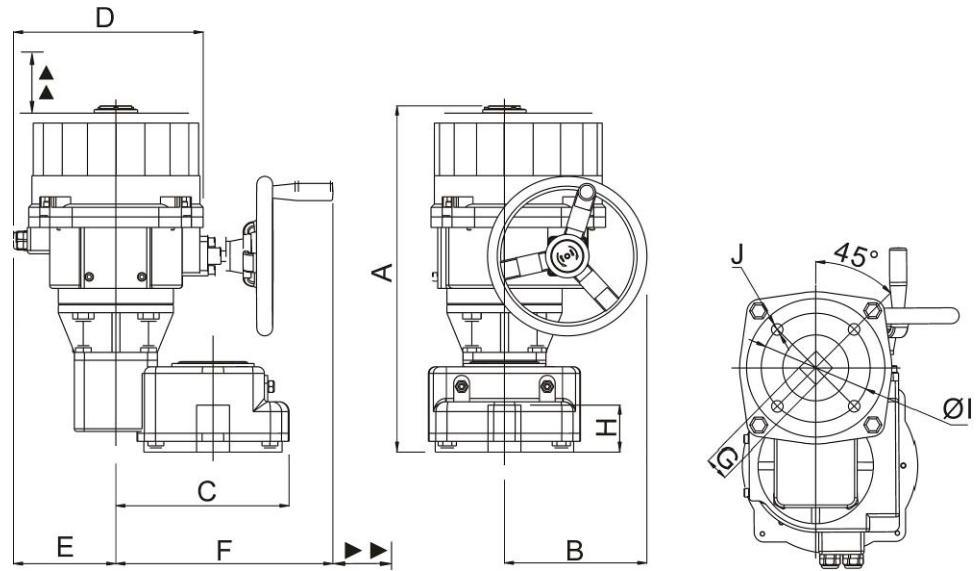

N4520M03

Product No.	A	B	C	D	E	F	G □	H	Ø I	J	Weight [kg]	EN ISO 5211
SQL321B1400 SQL361B1400	541	218	263	295	162	344	36	85	140	4-M16	76	F14
SQL321B2650 SQL361B2650	541	218	263	295	162	344	46	85	165	4-M20	76	F16

▲ ▶▶ ≥ 200 mm: For mounting, connection, operation, service, etc.

Revision numbers

Product No.	Valid from Rev. No.	Product No.	Valid from Rev. No.
SQL321B25	..B	-	-
SQL321B50	..B	SQL361B50	..B
SQL321B150	..B	SQL361B150	..B
SQL321B270	..B	SQL361B270	..B
SQL321B570	..B	SQL361B570	..B
SQL321B1400	..B	SQL361B1400	..B
SQL321B2650	..B	SQL361B2650	..B